

## Features

- Low capacitance
- Low distortion
- Surge protection
- RoHS compliant\*

## Applications

- G.Fast equipment
- xDSL modems and line cards

# TISP4G024L1W G.Fast VDSL Protector

## General Information

This device is designed to protect ADSL, VDSL and G.Fast line driver interfaces from overvoltages up to rated limits. Overvoltages are normally caused by a.c. power-system or lightning-flash disturbances which are induced or conducted onto the telephone line. This protector offers protection of both lines of the twisted wire pair in a single device.

When placed between the xDSL line driver IC and the transformer, this protector will clamp and switch into a low-impedance state, safely diverting the current transferred by the xDSL coupling transformer. The biased low capacitance design makes this device suitable for designs from ADSL to 30MHz VDSL2 to G.Fast.

Telecom ports need protection against longitudinal and transverse surges, to comply with international standards such as ITU-T K.20, K.21 or K.45, Telcordia GR-1089-CORE and YD/T. Longitudinal surges are resisted by the galvanic isolation of the coupling transformer which is commonly rated to 2 kV or greater. Transverse surges can be transmitted by the transformer, and can stress the Line Driver Interface IC. As the xDSL interface circuit is designed to operate from 3 kHz to 106 MHz, nearby high frequency events – such as cable flashover or primary protection activation – can generate damaging conditions for the interface requiring this type of protection.

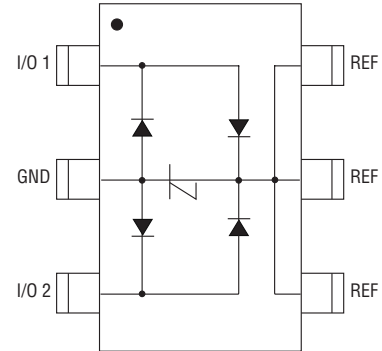

## Absolute Maximum Ratings, $T_A = 25\text{ }^\circ\text{C}$ (Unless Otherwise Noted)

Rating	Symbol	Rating	Unit
Repetitive Peak Off-State Voltage	$V_{\text{DRM}}$	24	V
Non-repetitive Peak Impulse Current, 8/20 $\mu\text{s}$	$I_{\text{PPSM}}$	30	A
ESD (IEC 61000-4-2 Contact)		8	kV
ESD (IEC 61000-4-2 Air)		15	kV
Junction Temperature	$T_J$	-40 to +150	$^\circ\text{C}$
Storage Temperature	$T_{\text{STG}}$	-55 to +150	$^\circ\text{C}$

## Electrical Characteristics, $T_A = 25\text{ }^\circ\text{C}$ (Unless Otherwise Noted)

Parameter	Test Condition (Note 1)	Min.	Typ.	Max.	Unit
$I_D$ Leakage Current	$V_D = V_{\text{DRM}}$			100	nA
$V_{(\text{BO})}$ Breakover Voltage	$di/dt = \pm 1\text{ mA}/\mu\text{s}$		30	34	V
$I_{(\text{BO})}$ Breakover Current	$di/dt = \pm 1\text{ mA}/\mu\text{s}$		80		mA
$V_T$ On-state Voltage	$I_T = \pm 1\text{ A}$		3.8		V
$V_T$ On-state Voltage	$I_T = 1\text{ A}$ , REF to GND		1		V
$I_H$ Holding Current	$I_T = \pm 5\text{ A}$ $di/dt = 1\text{ mA}/\mu\text{s}$		40		mA
C Capacitance	$V_D = 2\text{ V}$ , $f = 10\text{ MHz}$ , $V_d = 1\text{ Vrms}$		0.4	3	pF
$\Delta C$ Capacitance Variation	$V_D = 1\text{ V}$ to $V_{\text{DRM}}$ , $f = 10\text{ MHz}$ , $V_d = 1\text{ Vrms}$		0.02		pF

Note 1: All measurements made between I/O 1 and I/O 2 unless otherwise stated.

OCTOBER 2015

\*RoHS Directive 2002/95/EC Jan. 27, 2003 including annex and RoHS Recast 2011/65/EU June 8, 2011.

Specifications are subject to change without notice.

The device characteristics and parameters in this data sheet can and do vary in different applications and actual device performance may vary over time.

Users should verify actual device performance in their specific applications.

Parameter Measurement Information

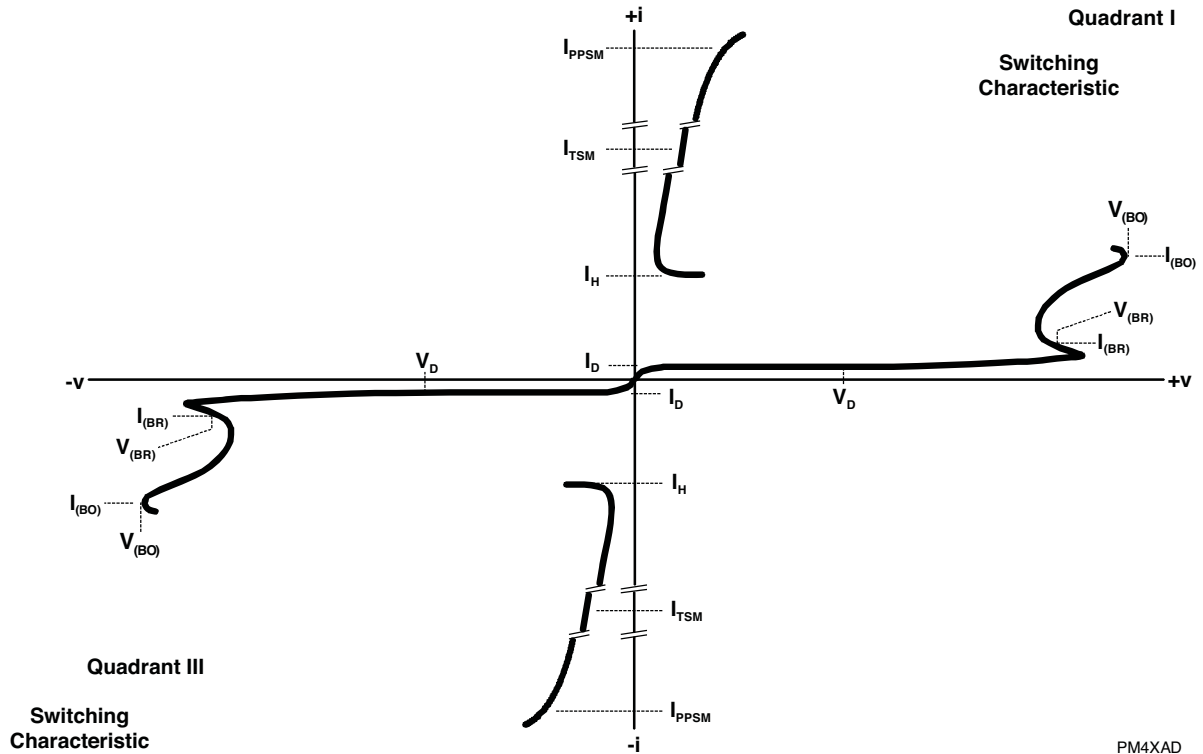

PM4XAD

Figure 1. Voltage-current Characteristic for I/O 1 to I/O 2

# TISP4G024L1W G.Fast VDSL Protector



## Typical Characteristics

### 8/20 $\mu$ s Pulse Waveform

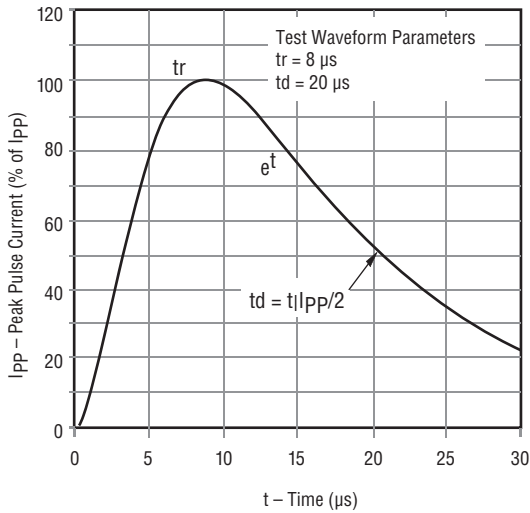

### Leakage Current vs Junction Temperature

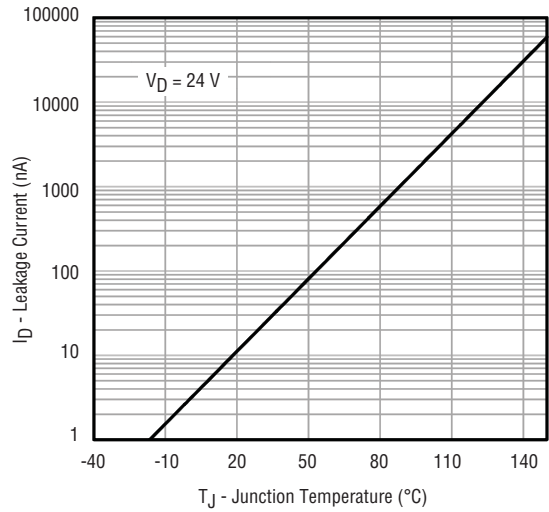

### Breakover Voltage vs Junction Temperature

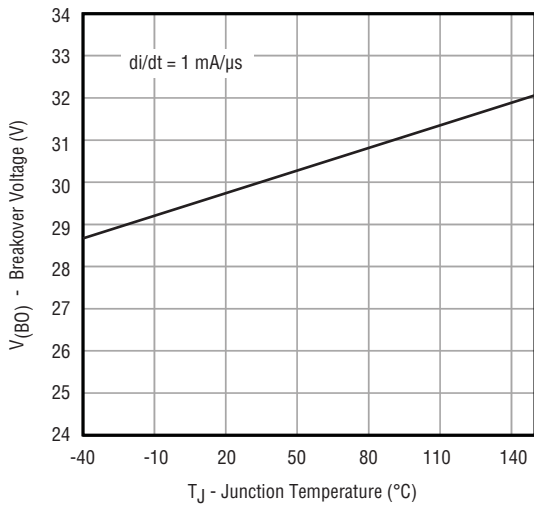

### Holding Current vs Junction Temperature

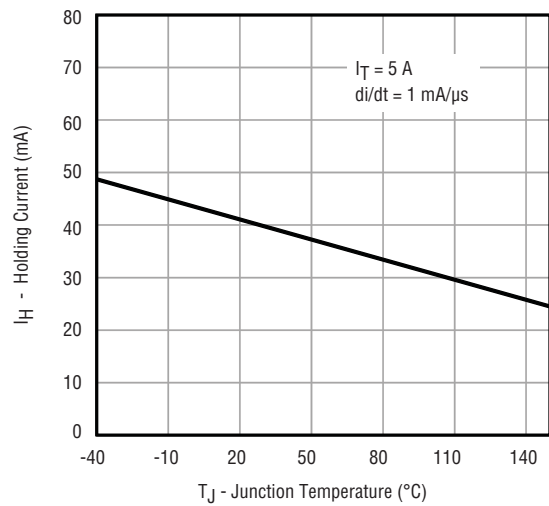

OCTOBER 2015

Specifications are subject to change without notice.

The device characteristics and parameters in this data sheet can and do vary in different applications and actual device performance may vary over time. Users should verify actual device performance in their specific applications.

## Typical Characteristics (Continued)

### On-State Voltage vs On-State Current

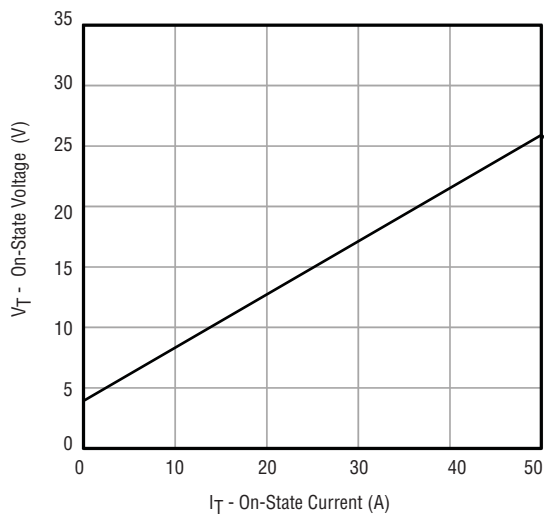

### Capacitance vs Off-State Voltage

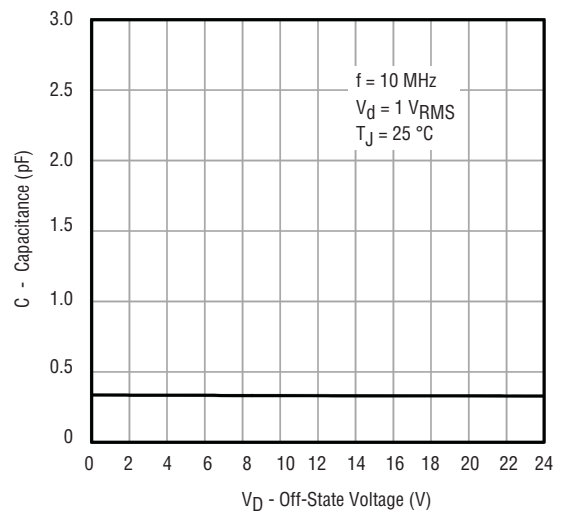

# TISP4G024L1W G.Fast VDSL Protector

**BOURNS®**

## Application Information

The Bourns® Model TISP4G024L1W is designed to protect xDSL and G.Fast line driver interfaces from overvoltage conditions up to rated limits. However, it can be used in other applications as well. The typical breakover voltage and current are specified as 30 V and 80 mA, respectively. It has a repetitive peak off-state voltage rating of 24 V and a peak current rating of 30 A for an 8/20  $\mu$ s current waveform.

Figure 1 shows a typical G.Fast application circuit which uses the TISP4G024L1W device for protection on the line driver side of the signal transformer. Two series resistors (typically 50 ohms each when a 1:1 transformer is used) which terminate the differential signal pair may be placed between the line driver outputs and the connections to the protection device and transformer. These resistors will also limit the current that the line driver is subjected to during a surge event. The signal lines are ac coupled between the transformer and the I/O (Input/output) connector.

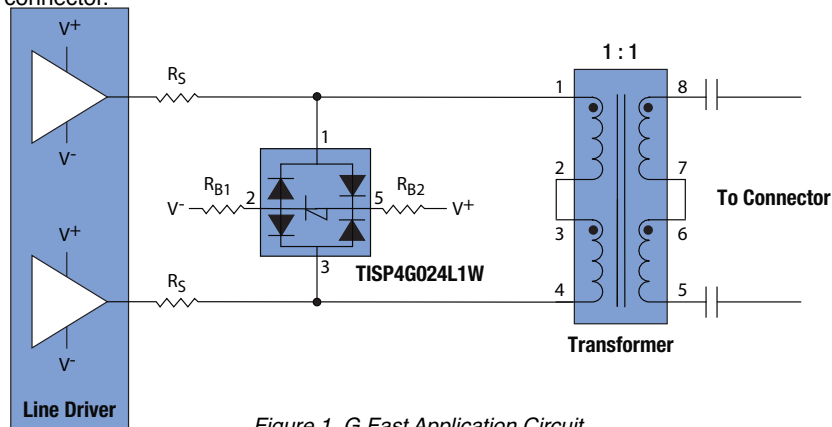

Figure 1. G.Fast Application Circuit

## Surge Protection in a G.Fast Application

In xDSL and G.Fast applications, the port is typically required to remain operational after being subjected to 10/700  $\mu$ s transverse surges up to 4 kV and longitudinal surges up to 6 kV when primary protection is used (ITU-T K.20, K.21 and K.44).

## Transverse Surge Test

The surge performance of Figure 1 is characterized using a modified circuit shown in Figure 2, where the line driver and series resistors were replaced with a single 100 ohm load resistor. Two 56 nF ac coupling caps are used to give an input capacitance of 28 nF, within the typical range of 27 to 33 nF that is used in xDSL and G.Fast applications. A Bourns® Model 2026-42-C2LF gas discharge tube (GDT) is used as the primary protector for this evaluation.

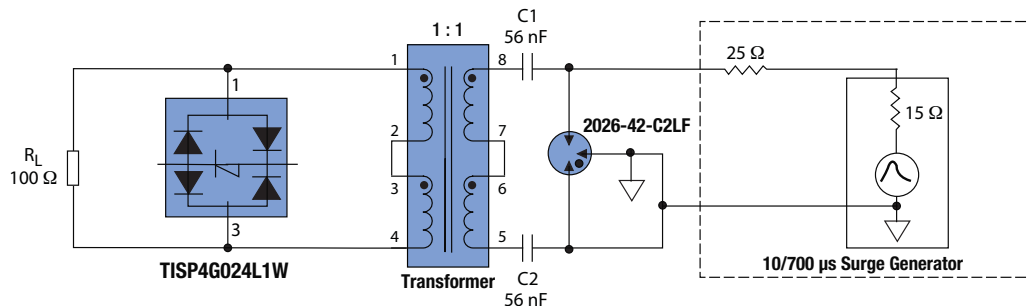

Figure 2. Transverse Surge Test Circuit in a G.Fast Application

OCTOBER 2015

Specifications are subject to change without notice.

The device characteristics and parameters in this data sheet can and do vary in different applications and actual device performance may vary over time. Users should verify actual device performance in their specific applications.

## Application Information (Continued)

## Transverse Surge Test (Continued)

Figure 3 shows the response of the design to a 4 kV transverse surge. The ac coupling capacitors (C1 and C2) are being charged by the surge current prior to the GDT firing. When the GDT fires (at 980 V), the voltage on the input lines is rapidly reduced to a low level, resulting in a damped oscillation across the input side of the transformer, which is coupled directly to the load side. The peak current on the load side of the transformer reaches 150 A during the first half cycle. The TISP4G024L1W device clamps to ~90 V at this current. The damped oscillation in this case lasts ~3 cycles, quickly decaying within 2  $\mu$ s. No components in the circuit were damaged during the test.

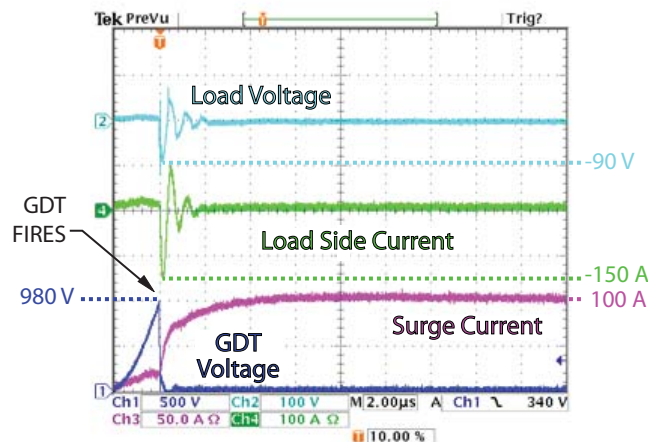

Figure 3. 4 kV 10/700  $\mu$ s Transverse Surge Response

## Longitudinal Surge Response

Figure 4 shows the same application circuit as Figure 3, but with the test generator now configured to perform longitudinal surge tests. Figure 5 shows the response of the design to a 6 kV 10/700  $\mu$ s longitudinal surge. Voltage on both lines reaches 980 V before the one side of the GDT fires, on Line 1 in this case, providing a path to ground for both lines. Subsequently, surge current will also flow from Line 2 through the input capacitors into ground via Line 1. When the input capacitors charge the Line 2 voltage to 820 V, the other side of the GDT fires. At this point, the response will be similar to that of the transverse surge, however, the surge current and voltage are lower since the GDT fired at a lower voltage.

While the capacitors are charging, the peak current on the load side of the transformer reaches 28 A and the TISP4G024L1W device clamps the voltage across the load below 20 V. After the second half of the GDT fires the damped oscillation begins, lasting about 3 cycles. The peak current on the load side is approximately 115 A with the TISP4G024L1W device clamping to 60 V. No components in the circuit were damaged during the test.

This longitudinal surge response demonstrates one of three possible scenarios when a three terminal GDT is used as the primary protector. The other two possibilities are: 1) Both sides of the GDT fire at the same or very close to the same time; and 2) the Line 2 side of the GDT fires before the Line 1 side. If both sides fire at the same time there will be a minimal amount of transverse current flowing through the transformer and, therefore, very little stress on the circuit as the primary protector will absorb almost all of the surge energy. If Line 2 fires before Line 1, the response will be similar to the one shown, except that the polarities of the voltages and currents on the load side of the transformer will be reversed. The peak voltages and currents on the load side of the transformer will be directly proportional to the peak voltage at which the second half of the GDT fires.

## Application Information (Continued)

### Longitudinal Surge Response (Continued)

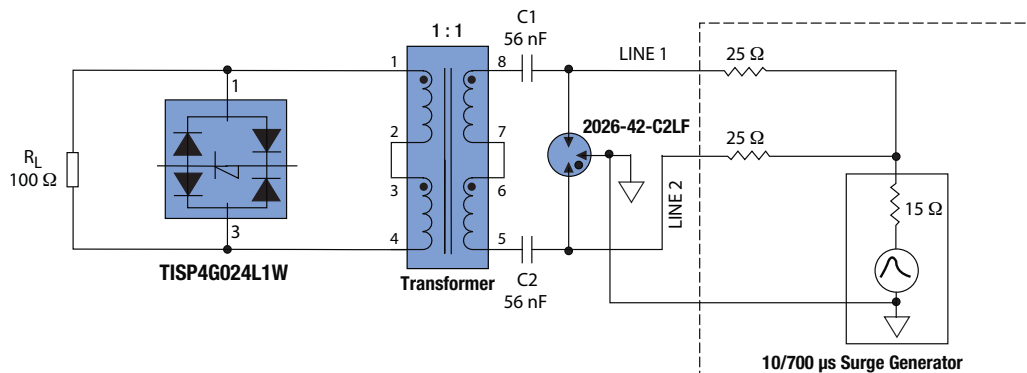

Figure 4. Longitudinal Surge Test Circuit for a G.Fast Application

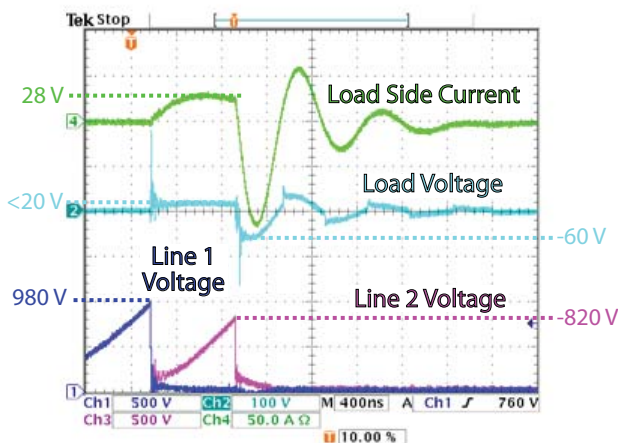

Figure 5. 6 kV Longitudinal Surge Response

### External Biasing

When the TISP4G024L1W device is not biased externally, the capacitance of the device will have to be charged by the line signal. The device leakage current will act to discharge this capacitance. When the signal level is lower than the voltage across this capacitance, the capacitive loading on the signal will be negligible. Conversely, when the signal level is higher than the voltage across this capacitance, there will be significant capacitive loading on the signal as the signal must again charge this capacitance. To avoid signal distortion which will adversely impact transmission performance, the TISP4G024L1W device should be biased externally.

Figure 6 shows a simple bias circuit for the TISP4G024L1W device which can be used to eliminate such signal distortion. For dual supply operation, resistors RB1 and RB2 are connected to the negative and positive supply rails used by the line driver, respectively. For applications that use a single positive supply, RB2 should be connected to the positive supply rail. Pin 2 can be connected directly to ground. The resistor value should be chosen so that the voltage drop across it ( $I_L \times R$ ) will not impact signal integrity at the maximum operating temperature of the application. Typical values will be in the range of 100K ohms to 1 megohm.

## Application Information (Continued)

### External Biasing (Continued)

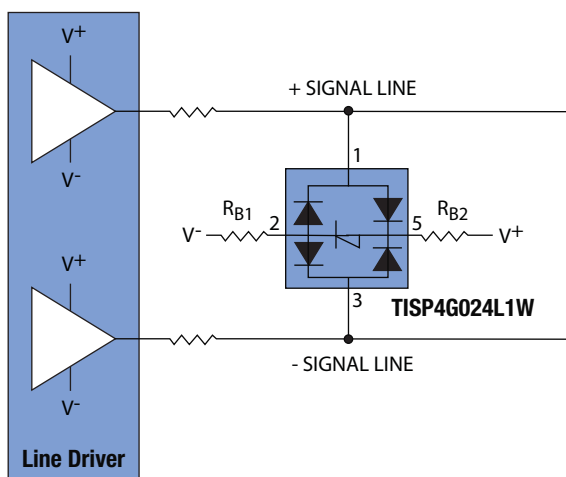

Figure 6. Bias Circuit for the Model TISP4G024L1W

### Summary

Bourns® Model TISP4G024L1W is designed to protect xDSL and G.Fast line driver interfaces from overvoltage conditions. Its typical performance when the port is subjected to 4 kV transverse surges and 6 kV longitudinal surges is shown above. The schematics above illustrate the application protection and do not constitute the complete circuit design. Customers should verify actual device performance in their specific applications.



# TISP4G024L1W G.Fast VDSL Protector



## Product Dimensions

This is a molded SOT23-6L package with RoHS compliant 100 % Matte Sn on the lead frame with a flammability rating of UL 94V-0.

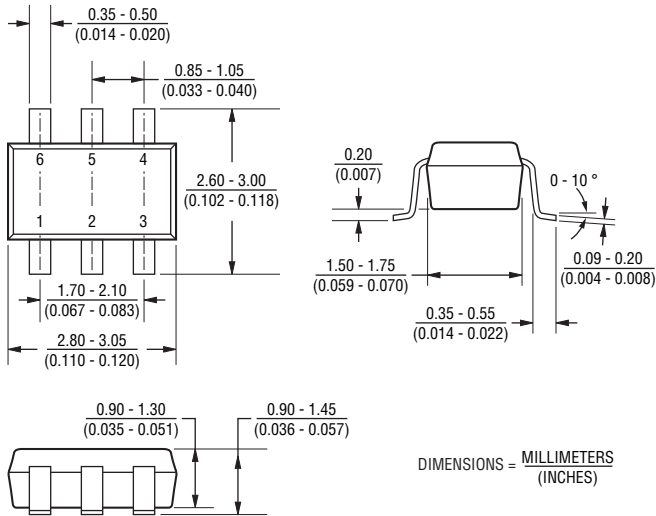

## Recommended Footprint

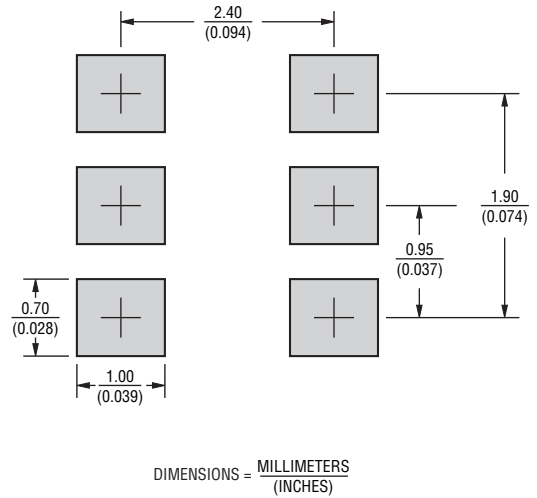

## Typical Part Marking

TISP4G024L1W .....G24

## How to Order

**TISP 4G 024 L 1 W R - S**

Common Code \_\_\_\_\_  
TISP® Device

Series \_\_\_\_\_  
4G = Single Bidirectional xDSL Protector

Repetitive Peak Off-State Voltage \_\_\_\_\_  
024 =  $24 V_{DRM}$

Surge Current ( $8/20 \mu s$ ) \_\_\_\_\_  
L = 30 A

Holding Current \_\_\_\_\_  
1 = Low  $I_H$

Device Package \_\_\_\_\_  
W = SOT23-6L

Packaging \_\_\_\_\_  
R = 7 inch reel

RoHS Compliancy \_\_\_\_\_  
S = RoHS compliant

OCTOBER 2015

Specifications are subject to change without notice.

The device characteristics and parameters in this data sheet can and do vary in different applications and actual device performance may vary over time. Users should verify actual device performance in their specific applications.

# TISP4G024L1W G.Fast VDSL Protector

**BOURNS®**

## Packaging Information

The product is packaged in tape and reel format per EIA-481 standard.

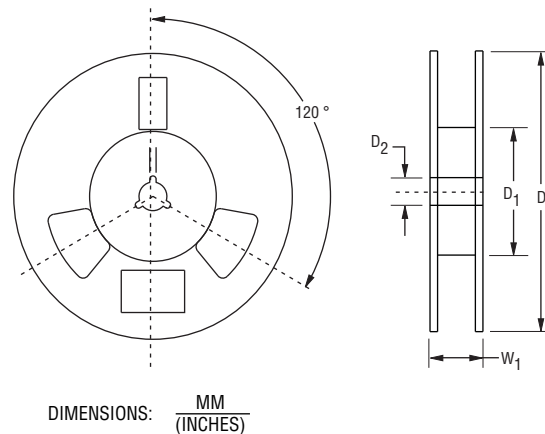
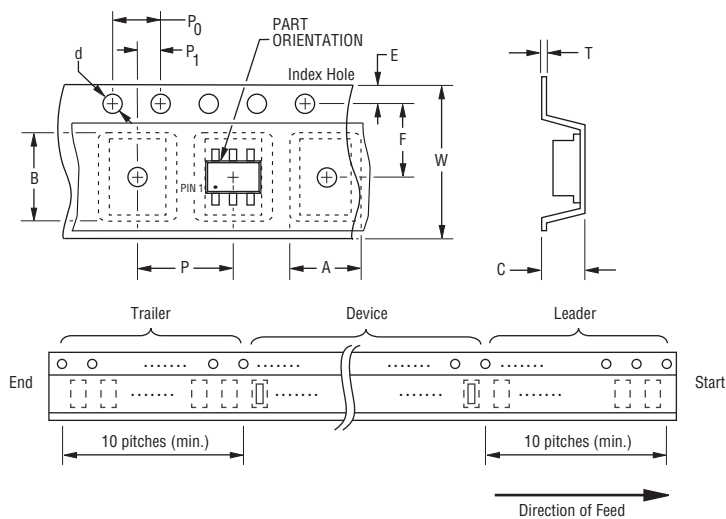

Item	Symbol	SOT23-6
Carrier Width	A	$\frac{3.90 \pm 0.10}{(0.154 \pm 0.004)}$
Carrier Length	B	$\frac{3.90 \pm 0.10}{(0.154 \pm 0.004)}$
Carrier Depth	C	$\frac{0.90 \pm 0.10}{(0.035 \pm 0.004)}$
Sprocket Hole	d	$\frac{1.55 \pm 0.05}{(0.061 \pm 0.002)}$
Reel Outside Diameter	D	$\frac{178}{(7.008)}$
Reel Inner Diameter	D <sub>1</sub>	$\frac{50.0}{(1.969)}$ MIN.
Feed Hole Diameter	D <sub>2</sub>	$\frac{13.0 \pm 0.20}{(0.512 \pm 0.008)}$
Sprocket Hole Position	E	$\frac{1.75 \pm 0.10}{(0.069 \pm 0.004)}$
Punch Hole Position	F	$\frac{3.50 \pm 0.05}{(0.138 \pm 0.002)}$
Punch Hole Pitch	P	$\frac{4.00 \pm 0.10}{(0.157 \pm 0.004)}$
Sprocket Hole Pitch	P <sub>0</sub>	$\frac{4.00 \pm 0.10}{(0.157 \pm 0.004)}$
Embossment Center	P <sub>1</sub>	$\frac{2.00 \pm 0.05}{(0.079 \pm 0.002)}$
Overall Tape Thickness	T	$\frac{0.20 \pm 0.10}{(0.008 \pm 0.004)}$
Tape Width	W	$\frac{8.00 \pm 0.20}{(0.315 \pm 0.008)}$
Reel Width	W <sub>1</sub>	$\frac{14.4}{(0.567)}$ MAX.
Quantity per Reel	--	3000

**BOURNS®**

### Asia-Pacific:

Tel: +886-2 2562-4117

Fax: +886-2 2562-4116

### EMEA:

Tel: +36 88 520 390

Fax: +36 88 520 211

### The Americas:

Tel: +1-951 781-5500

Fax: +1-951 781-5700

[www.bourns.com](http://www.bourns.com)

OCTOBER 2015

Specifications are subject to change without notice.

The device characteristics and parameters in this data sheet can and do vary in different applications and actual device performance may vary over time. Users should verify actual device performance in their specific applications.

# Mouser Electronics

Authorized Distributor

Click to View Pricing, Inventory, Delivery & Lifecycle Information:

Bourns:

[TISP4G024L1WR-S](#)