



Is Now Part of



ON Semiconductor®

To learn more about ON Semiconductor, please visit our website at
www.onsemi.com

ON Semiconductor and the ON Semiconductor logo are trademarks of Semiconductor Components Industries, LLC dba ON Semiconductor or its subsidiaries in the United States and/or other countries. ON Semiconductor owns the rights to a number of patents, trademarks, copyrights, trade secrets, and other intellectual property. A listing of ON Semiconductor's product/patent coverage may be accessed at www.onsemi.com/site/pdf/Patent-Marking.pdf. ON Semiconductor reserves the right to make changes without further notice to any products herein. ON Semiconductor makes no warranty, representation or guarantee regarding the suitability of its products for any particular purpose, nor does ON Semiconductor assume any liability arising out of the application or use of any product or circuit, and specifically disclaims any and all liability, including without limitation special, consequential or incidental damages. Buyer is responsible for its products and applications using ON Semiconductor products, including compliance with all laws, regulations and safety requirements or standards, regardless of any support or applications information provided by ON Semiconductor. "Typical" parameters which may be provided in ON Semiconductor data sheets and/or specifications can and do vary in different applications and actual performance may vary over time. All operating parameters, including "Typicals" must be validated for each customer application by customer's technical experts. ON Semiconductor does not convey any license under its patent rights nor the rights of others. ON Semiconductor products are not designed, intended, or authorized for use as a critical component in life support systems or any FDA Class 3 medical devices or medical devices with a same or similar classification in a foreign jurisdiction or any devices intended for implantation in the human body. Should Buyer purchase or use ON Semiconductor products for any such unintended or unauthorized application, Buyer shall indemnify and hold ON Semiconductor and its officers, employees, subsidiaries, affiliates, and distributors harmless against all claims, costs, damages, and expenses, and reasonable attorney fees arising out of, directly or indirectly, any claim of personal injury or death associated with such unintended or unauthorized use, even if such claim alleges that ON Semiconductor was negligent regarding the design or manufacture of the part. ON Semiconductor is an Equal Opportunity/Affirmative Action Employer. This literature is subject to all applicable copyright laws and is not for resale in any manner.



June 2016

FOD410, FOD4108, FOD4116, FOD4118 6-Pin DIP Snubberless Zero-Cross Triac Drivers

Features

- 300 mA On-State Current
- Zero-Voltage Crossing
- High Blocking Voltage
 - 600 V (FOD410, FOD4116)
 - 800 V (FOD4108, FOD4118)
- High Trigger Sensitivity
 - 1.3 mA (FOD4116, FOD4118)
 - 2 mA (FOD410, FOD4108)
- High Static dv/dt (10,000 V/μs)
- Safety and Regulatory Approvals:
 - UL1577, 5,000 VAC_{RMS} for 1 Minute
 - DIN-EN/IEC60747-5-5

Description

The FOD410, FOD4108, FOD4116 and FOD4118 devices consist of an infrared emitting diode coupled to a hybrid triac formed with two inverse parallel SCRs which form the triac function capable of driving discrete triacs. The FOD4116 and FOD4118 utilize a high efficiency infrared emitting diode which offers an improved trigger sensitivity. These devices are housed in a standard 6-pin dual in-line (DIP) package.

Applications

- Solid-State Relays
- Industrial Controls
- Lighting Controls
- Static Power Switches
- AC Motor Starters

Functional Schematic

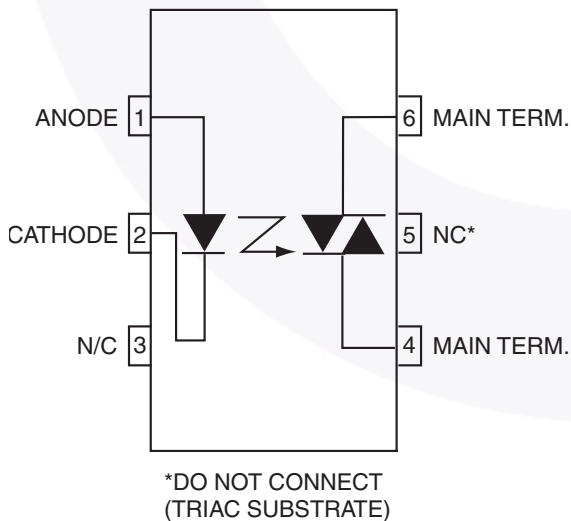

Figure 1. Schematic

Package Outlines

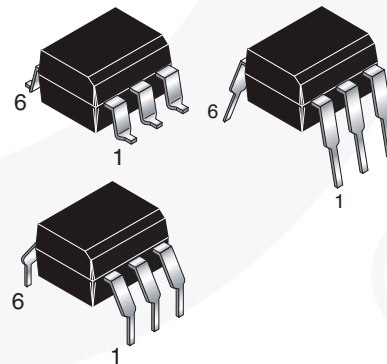

Figure 2. Package Outlines

FOD410, FOD4108, FOD4116, FOD4118 — 6-Pin DIP Snubberless Zero-Cross Triac Drivers

Safety and Insulation Ratings

As per DIN EN/IEC 60747-5-5, this optocoupler is suitable for “safe electrical insulation” only within the safety limit data. Compliance with the safety ratings shall be ensured by means of protective circuits.

Parameter	Characteristics
Installation Classifications per DIN VDE 0110/1.89 Table 1, For Rated Mains Voltage	< 150 V _{RMS}
	< 300 V _{RMS}
Climatic Classification	55/100/21
Pollution Degree (DIN VDE 0110/1.89)	2
Comparative Tracking Index	175

Symbol	Parameter	Value	Unit
V _{PR}	Input-to-Output Test Voltage, Method A, V _{IORM} × 1.6 = V _{PR} , Type and Sample Test with t _m = 10 s, Partial Discharge < 5 pC	1360	V _{peak}
	Input-to-Output Test Voltage, Method B, V _{IORM} × 1.875 = V _{PR} , 100% Production Test with t _m = 1 s, Partial Discharge < 5 pC	1594	V _{peak}
V _{IORM}	Maximum Working Insulation Voltage	850	V _{peak}
V _{IOTM}	Highest Allowable Over-Voltage	6000	V _{peak}
	External Creepage	≥ 7	mm
	External Clearance	≥ 7	mm
DTI	Distance Through Insulation (Insulation Thickness)	≥ 0.4	mm
T _S	Case Temperature ⁽¹⁾	175	°C
I _{S,INPUT}	Input Current ⁽¹⁾	400	mA
P _{S,OUTPUT}	Output Power ⁽¹⁾	700	mW
R _{IO}	Insulation Resistance at T _S , V _{IO} = 500 V ⁽¹⁾	> 10 ⁹	Ω

Note:

1. Safety limit values – maximum values allowed in the event of a failure.

Absolute Maximum Ratings

Stresses exceeding the absolute maximum ratings may damage the device. The device may not function or be operable above the recommended operating conditions and stressing the parts to these levels is not recommended. In addition, extended exposure to stresses above the recommended operating conditions may affect device reliability. The absolute maximum ratings are stress ratings only. $T_A = 25^\circ\text{C}$ unless otherwise specified.

Symbol	Parameter	Device	Value	Unit
T_{STG}	Storage Temperature	All	-55 to +150	$^\circ\text{C}$
T_{OPR}	Operating Temperature	All	-55 to +100	$^\circ\text{C}$
T_J	Junction Temperature	All	-55 to +125	$^\circ\text{C}$
T_{SOL}	Lead Solder Temperature	All	260 for 10 sec	$^\circ\text{C}$
$P_{D(TOTAL)}$	Total Device Power Dissipation @ 25 $^\circ\text{C}$	All	500	mW
	Derate Above 25 $^\circ\text{C}$	All	6.6	mW/ $^\circ\text{C}$
EMITTER				
I_F	Continuous Forward Current	All	30	A
V_R	Reverse Voltage	All	6	V
$P_{D(EMITTER)}$	Total Power Dissipation 25 $^\circ\text{C}$ Ambient	All	50	mW
	Derate Above 25 $^\circ\text{C}$	All	0.71	mW/ $^\circ\text{C}$
DETECTOR				
V_{DRM}	Off-State Output Terminal Voltage	FOD410, FOD4116	600	V
		FOD4108, FOD4118	800	
I_{TSM}	Peak Non-Repetitive Surge Current (single cycle 60 Hz sine wave)	All	3	A
I_{TM}	Peak On-State Current	All	300	mA
$P_{D(DETECTOR)}$	Total Power Dissipation @ 25 $^\circ\text{C}$ Ambient	All	450	mW
	Derate Above 25 $^\circ\text{C}$	All	5.9	mW/ $^\circ\text{C}$

Electrical Characteristics

$T_A = 25^\circ\text{C}$ unless otherwise specified.

Individual Component Characteristics

Symbol	Parameter	Test Conditions	Device	Min.	Typ.	Max.	Unit
EMITTER							
V_F	Input Forward Voltage	$I_F = 20\text{ mA}$	All		1.25	1.50	V
I_R	Reverse Leakage Current	$V_R = 6\text{ V}$	All		0.0001	10	μA
DETECTOR							
$I_{D(RMS)}$	Peak Blocking Current Either Direction	$I_F = 0,$ $T_A = 100^\circ\text{C}^{(2)}$	$V_D = 600\text{ V}$	FOD410, FOD4116	3	100	μA
			$V_D = 800\text{ V}$	FOD4108, FOD4118			
$I_{R(RMS)}$	Reverse Current	$T_A = 100^\circ\text{C}$	$V_D = 600\text{ V}$	FOD410, FOD4116	3	100	μA
			$V_D = 800\text{ V}$	FOD4108, FOD4118			
dv/dt	Critical Rate of Rise of Off-State Voltage	$I_F = 0^{(3)}$ (Figure 15)	All	10,000			V/ μs

Notes:

2. Test voltage must be applied within dv/dt rating.
3. This is static dv/dt. See Figure 15 for test circuit. Commutating dv/dt is a function of the load-driving thyristor(s) only.

Electrical Characteristics (Continued)

$T_A = 25^\circ\text{C}$ unless otherwise specified.

Transfer Characteristics

Symbol	Parameter	Test Conditions	Device	Min.	Typ.	Max.	Unit
I_{FT}	LED Trigger Current	Main Terminal Voltage = 5 V ⁽⁴⁾	FOD410, FOD4108		0.65	2.0	mA
			FOD4116, FOD4118		0.65	1.3	
V_{TM}	Peak On-State Voltage, Either Direction	$I_{TM} = 300\text{ mA peak}$, $I_F = \text{Rated } I_{FT}$	All		2.2	3	V
I_H	Holding Current, Either Direction	$V_T = 3\text{ V}$	All		200	500	μA
I_L	Latching Current	$V_T = 2.2\text{ V}$	All		5		mA
t_{ON}	Turn-On Time	PF = 1.0, $I_T = 300\text{ mA}$	$V_{RM} = V_{DM} = 424\text{ VAC}$	FOD410, FOD4116, FOD4118		60	μs
			$V_{RM} = V_{DM} = 565\text{ VAC}$	FOD4108			
t_{OFF}	Turn-Off Time		$V_{RM} = V_{DM} = 424\text{ VAC}$	FOD410, FOD4116, FOD4118		52	μs
			$V_{RM} = V_{DM} = 565\text{ VAC}$	FOD4108			
dv/dt_{crq}	Critical Rate of Rise of Voltage at Current Commutation	$V_D = 0.67 V_{DRM}$, $di/dt_{crq} \leq 15\text{ A/ms}$	$T_J = 25^\circ\text{C}$	All	10,000		$\text{V}/\mu\text{s}$
			$T_J = 80^\circ\text{C}$		5,000		$\text{V}/\mu\text{s}$
di/dt_{cr}	Critical Rate of Rise of On-State Current		All			8	$\text{A}/\mu\text{s}$
$dv(IO)/dt$	Critical Rate of Rise of Coupled Input/Output Voltage	$I_T = 0\text{ A}$, $V_{RM} = V_{DM} = 424\text{ VAC}$	All		10,000		$\text{V}/\mu\text{s}$

Note:

4. All devices are guaranteed to trigger at an I_F value less than or equal to max I_{FT} . Therefore, recommended operating I_F lies between max I_{FT} (2 mA for FOD410 and FOD4108 and 1.3 mA for FOD4116 and FOD4118) and the absolute max I_F (60 mA).

Zero Crossing Characteristics

Symbol	Parameter	Test Conditions	Device	Min.	Typ.	Max.	Unit
V_{INH}	Inhibit Voltage (MT1-MT2 Voltage above which device will not trigger)	$I_F = \text{Rated } I_{FT}$	All		8	25	V
I_{DRM2}	Leakage in Inhibit State	$I_F = \text{Rated } I_{FT}$, Rated V_{DRM} , Off-State	All		20	200	μA

Isolation Characteristics

Symbol	Parameter	Test Conditions	Device	Min.	Typ.	Max.	Unit
V_{ISO}	Steady State Isolation Voltage	$f = 60\text{ Hz}$, $t = 1\text{ Minute}^{(5)}$	All	5,000			VAC_{RMS}

Note:

5. Isolation voltage, V_{ISO} , is an internal device dielectric breakdown rating. For this test, pins 1, 2 and 3 are common, and pins 4, 5 and 6 are common. 5,000 VAC_{RMS} for 1 minute duration is equivalent to 6,000 VAC_{RMS} for 1 second duration.

Typical Application

Figure 3 shows a typical circuit for when hot line switching is required. In this circuit the “hot” side of the line is switched and the load connected to the cold or neutral side. The load may be connected to either the neutral or hot line.

R_{in} is calculated so that I_F is equal to the rated I_{FT} of the part, 2 mA for FOD420 and FOD4208, 1.3 mA for FOD4216 and FOD4218. The 39 Ω resistor and 0.01 μF capacitor are for snubbing of the triac and may or may not be necessary depending upon the particular triac and load use.

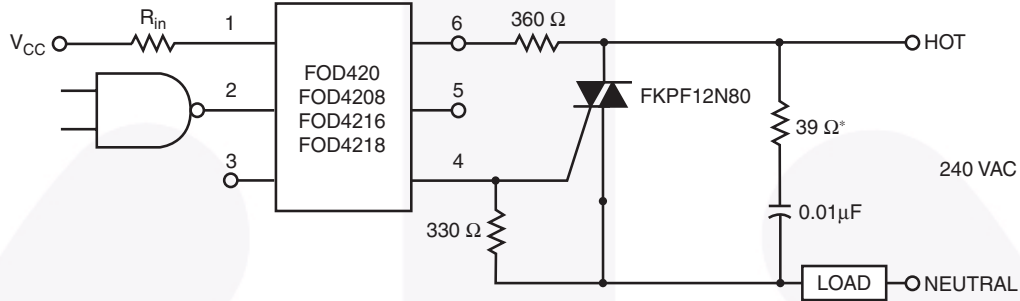

* For highly inductive loads (power factor < 0.5), change this value to 360 ohms.

Figure 3. Hot-Line Switching Application Circuit

Typical Performance Characteristics

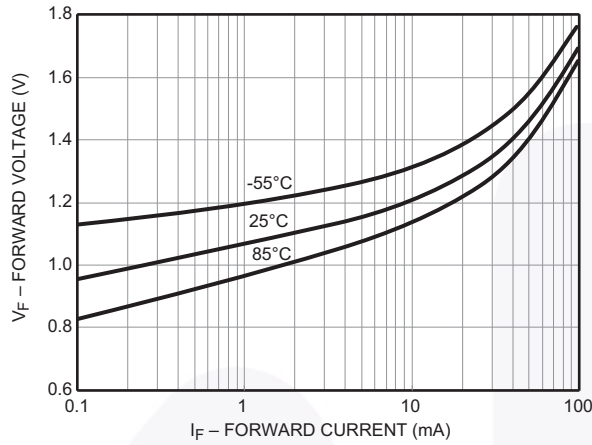

Figure 4. Forward Voltage (V_F) vs. Forward Current (I_F)

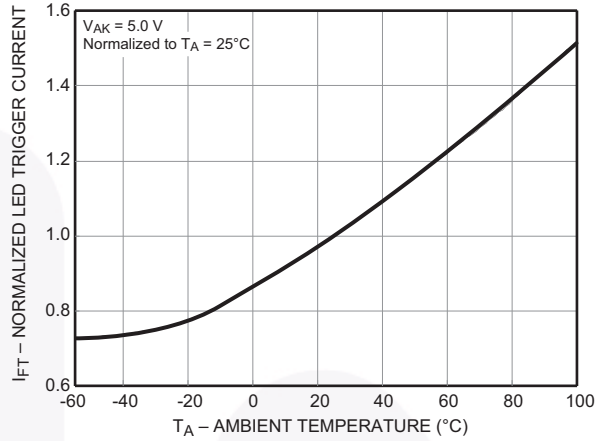

Figure 5. Normalized LED Trigger Current (I_{FT}) vs. Ambient Temperature (T_A)

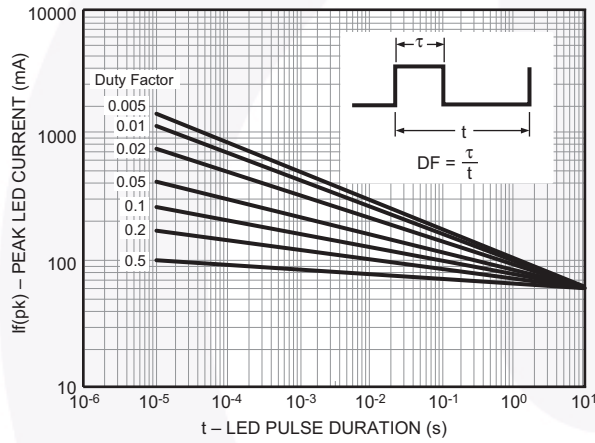

Figure 6. Peak LED Current vs. Duty Factor, Tau

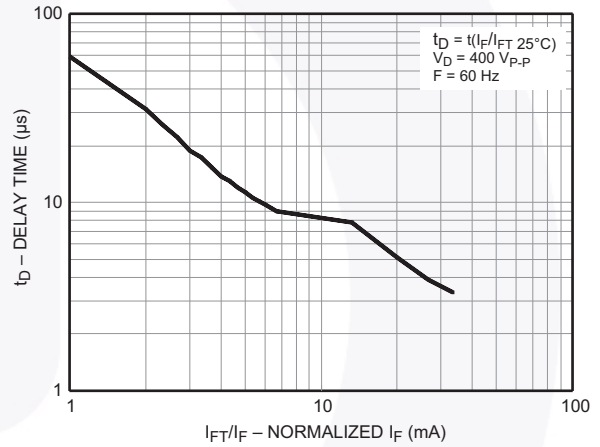

Figure 7. Trigger Delay Time

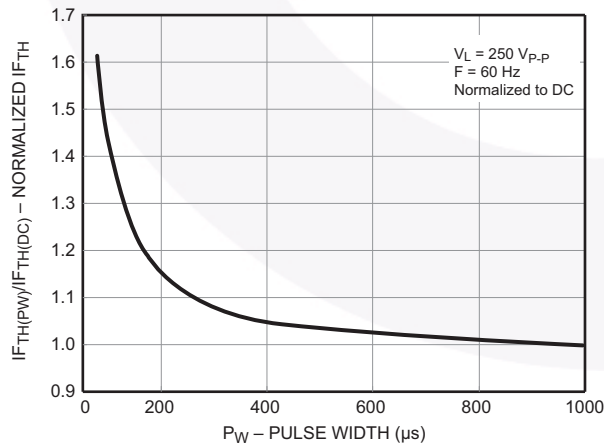

Figure 8. Pulse Trigger Current

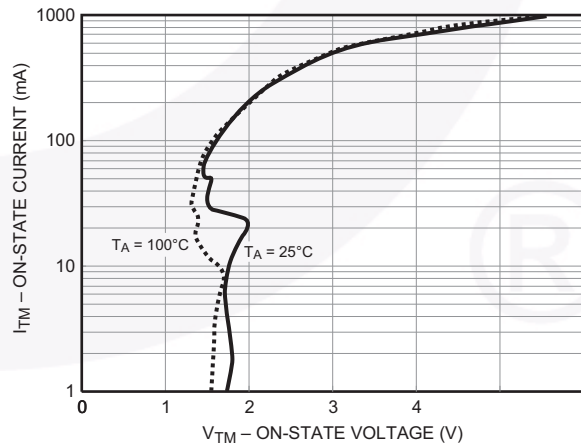

Figure 9. On-State Voltage (V_{TM}) vs. On-State Current (I_{TM})

Typical Performance Characteristics (Continued)

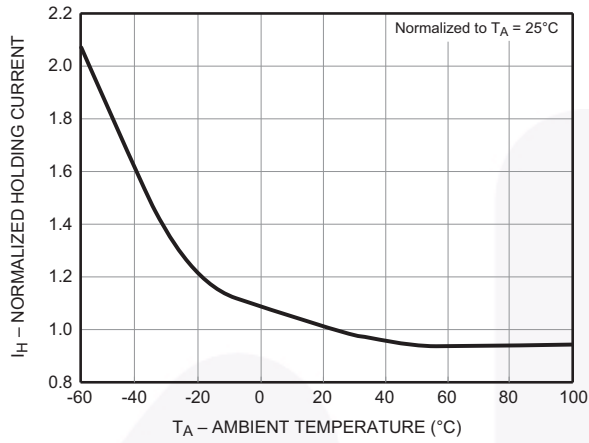

Figure 10. Normalized Holding Current (I_H) vs. Ambient Temperature (T_A)

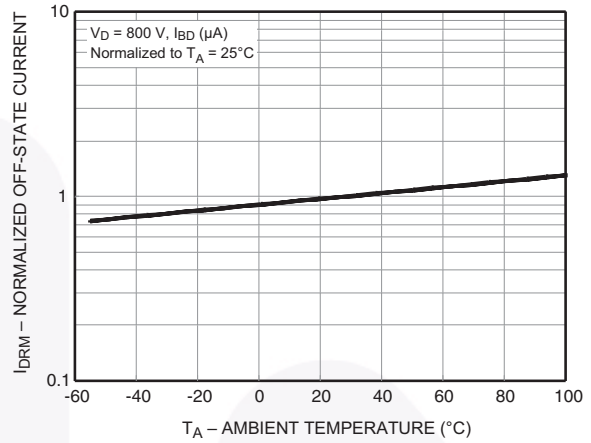

Figure 11. Normalized Off-State Current (I_{DRM}) vs. Ambient Temperature (T_A)

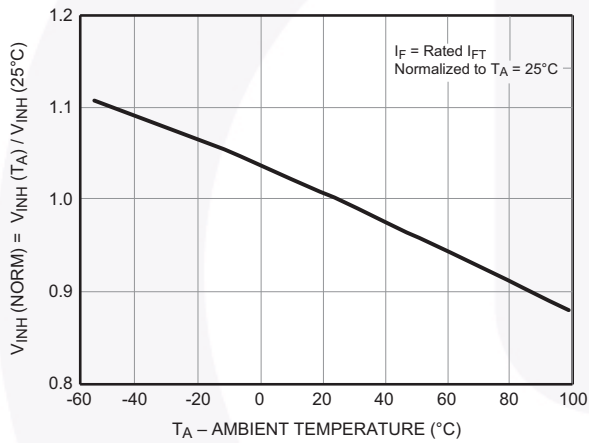

Figure 12. Normalized Inhibit Voltage (V_{INH}) vs. Ambient Temperature (T_A)

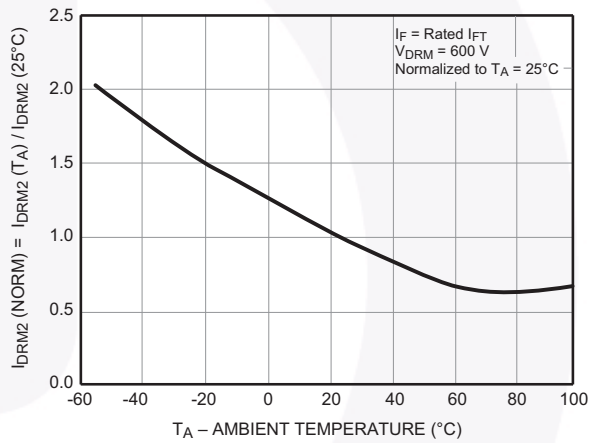

Figure 13. Normalized Leakage in Inhibit State (I_{DRM2}) vs. Ambient Temperature (T_A)

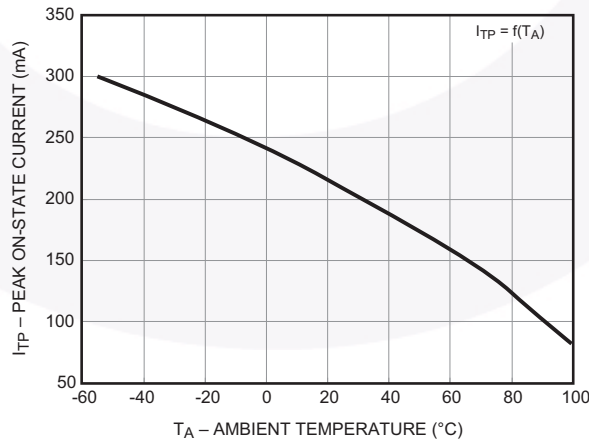
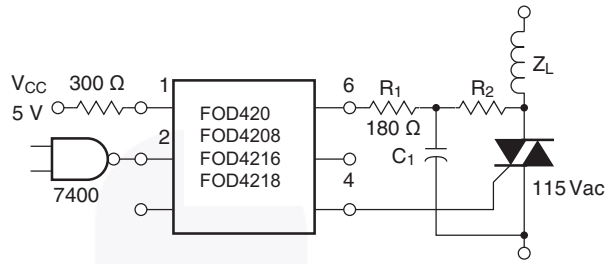

Figure 14. Current Reduction



NOTE: Circuit supplies 25 mA drive to gate of triac at $V_{in} = 25\text{ V}$ and $T_A < 70^\circ\text{C}$

TRIAC		
I_{GT} (mA)	R_2 (Ω)	C_1 (μF)
15	2400	0.1
30	1200	0.2
50	800	0.3

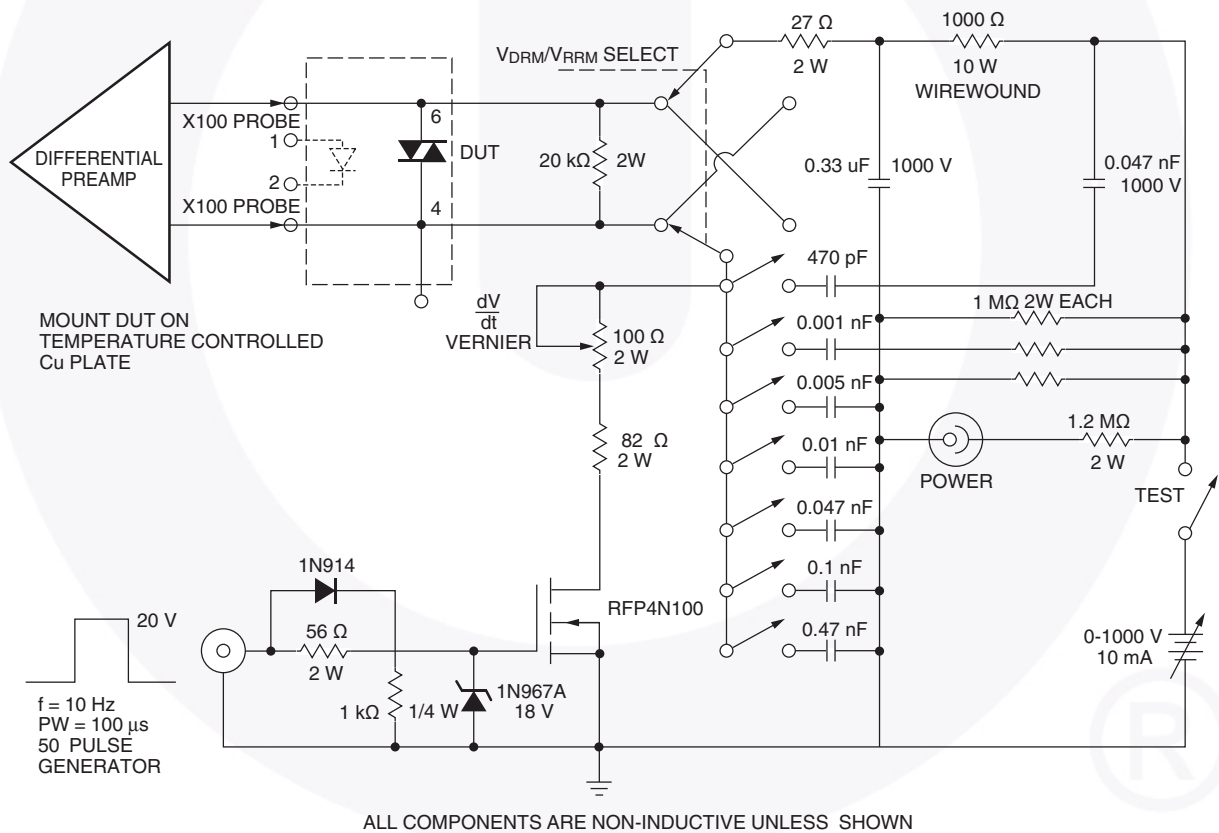

Figure 13. Circuit for Static $\frac{dv}{dt}$ Measurement of Power Thyristors

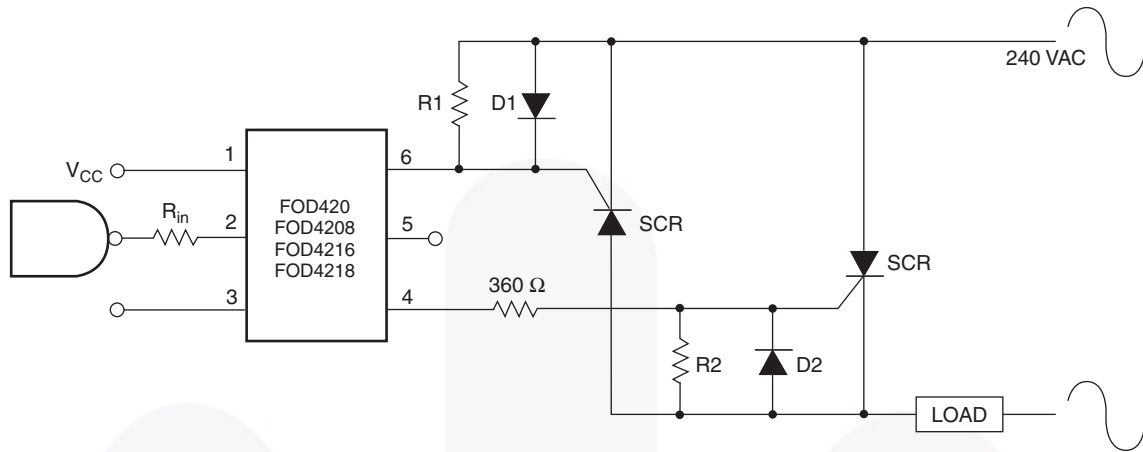
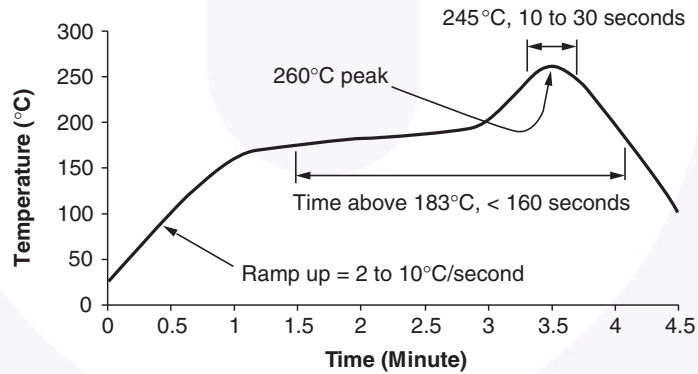

Figure 14. Inverse-Parallel SCR Driver Circuit

Suggested method of firing two, back-to-back SCR's with a Fairchild triac driver. Diodes can be 1N4001; resistors, R1 and R2, are optional 330 Ω .

Note: This optoisolator should not be used to drive a load directly. It is intended to be a discrete triac driver device only.

Reflow Profile



- Peak reflow temperature: 260°C (package surface temperature)
- Time of temperature higher than 183°C for 160 seconds or less
- One time soldering reflow is recommended

Figure 15. Reflow Profile

Ordering Information

Part Number	Package	Packing Method
FOD410	DIP 6-Pin	Tube (50 Units)
FOD410S	SMT 6-Pin (Lead Bend)	Tube (50 Units)
FOD410SD	SMT 6-Pin (Lead Bend)	Tape and Reel (1000 Units)
FOD410V	DIP 6-Pin, DIN EN/IEC60747-5-5 Option	Tube (50 Units)
FOD410SV	SMT 6-Pin (Lead Bend), DIN EN/IEC60747-5-5 Option	Tube (50 Units)
FOD410SDV	SMT 6-Pin (Lead Bend), DIN EN/IEC60747-5-5 Option	Tape and Reel (1000 Units)
FOD410TV	DIP 6-Pin, 0.4" Lead Spacing, DIN EN/IEC60747-5-5 Option	Tube (50 Units)

Note:

6. The product orderable part number system listed in this table also applies to the FOD4108, FOD4116, and FOD4118 product families.

Marking Information

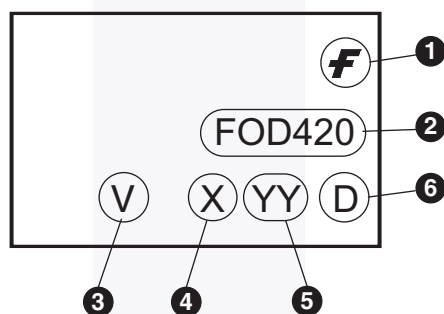
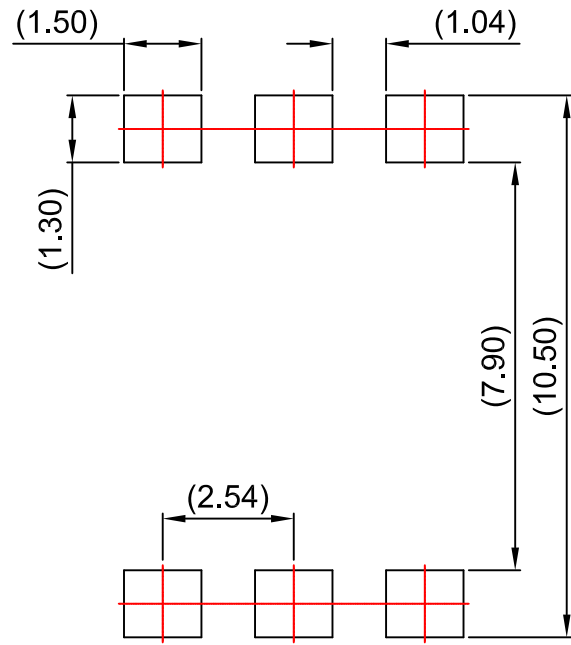

Figure 18. Top Mark

Table 1. Top Mark Definitions

1	Fairchild Logo
2	Device Number
3	VDE mark. DIN EN/IEC60747-5-5 Option (only appears on component ordered with this option)
4	One-Digit Year Code, e.g., "6"
5	Digit Work Week, Ranging from "01" to "53"
6	Assembly Package Code



LAND PATTERN RECOMMENDATION

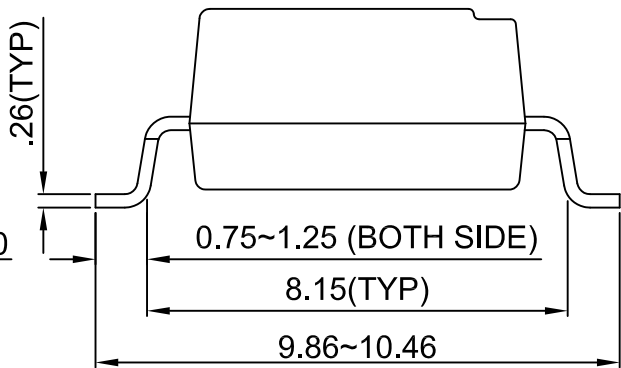
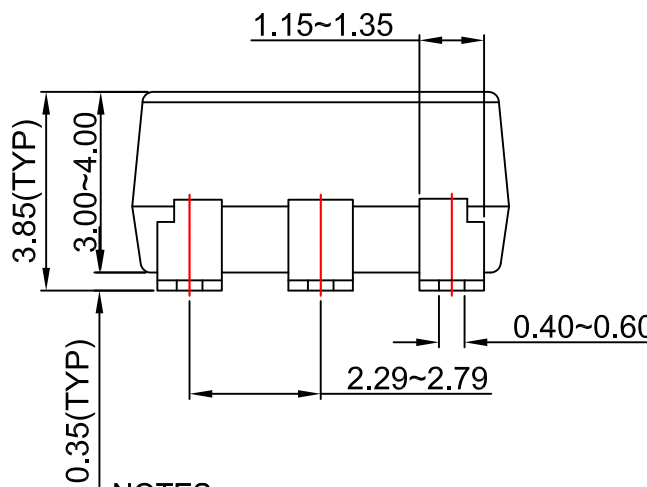

NOTES:

- A) NO STANDARD APPLIES TO THIS PACKAGE.
- B) ALL DIMENSIONS ARE IN MILLIMETERS.
- C) DIMENSIONS ARE EXCLUSIVE OF BURRS, MOLD FLASH, AND TIE BAR EXTRUSION
- D) DRAWING FILENAME AND REVISION: MKT-N06rev2.





NOTES:

- A) NO STANDARD APPLIES TO THIS PACKAGE.
- B) ALL DIMENSIONS ARE IN MILLIMETERS.
- C) DIMENSIONS ARE EXCLUSIVE OF BURRS, MOLD FLASH, AND TIE BAR EXTRUSION
- D) DRAWING FILENAME AND REVISION: MKT-N06Erev2.





NOTES:

- A) NO STANDARD APPLIES TO THIS PACKAGE.
- B) ALL DIMENSIONS ARE IN MILLIMETERS.
- C) DIMENSIONS ARE EXCLUSIVE OF BURRS, MOLD FLASH, AND TIE BAR EXTRUSION
- D) DRAWING FILENAME AND REVISION: MKT-N06Grev2.

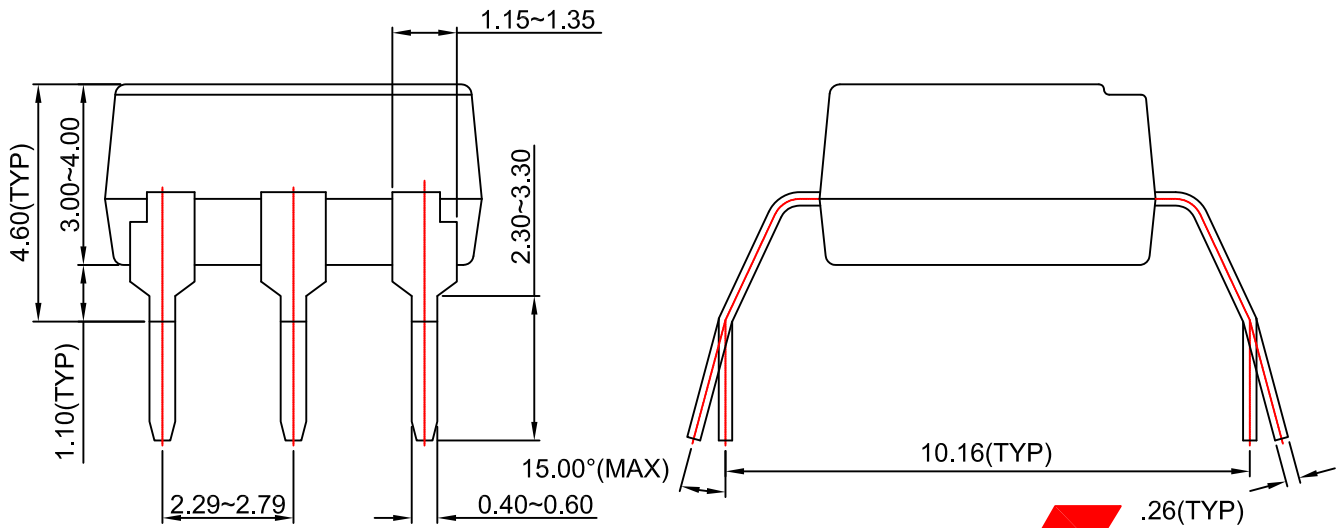



TRADEMARKS

The following includes registered and unregistered trademarks and service marks, owned by Fairchild Semiconductor and/or its global subsidiaries, and is not intended to be an exhaustive list of all such trademarks.

- | | | | |
|--------------------------|--|---------------------------------------|------------------|
| AccuPower™ | F-PFS™ | OPTOPLANAR® | SYSTEM GENERAL® |
| AttitudeEngine™ | FRFET® | Power Supply WebDesigner™ | TinyBoost® |
| Awinda® | Global Power Resource SM | PowerTrench® | TinyBuck® |
| AX-CAP®* | GreenBridge™ | PowerXS™ | TinyCalc™ |
| BitSiC™ | Green FPS™ | Programmable Active Droop™ | TinyLogic® |
| Build it Now™ | Green FPS™ e-Series™ | QFET® | TINYOPTO™ |
| CorePLUS™ | Gmax™ | QS™ | TinyPower™ |
| CorePOWER™ | GTO™ | Quiet Series™ | TinyPWM™ |
| CROSSVOL™ | IntelliMAX™ | RapidConfigure™ | TinyWire™ |
| CTL™ | ISOPLANAR™ | Saving our world, 1mW/W/kW at a time™ | TranSiC™ |
| Current Transfer Logic™ | Making Small Speakers Sound Louder and Better™ | SignalWise™ | TriFault Detect™ |
| DEUXPEED® | MegaBuck™ | SmartMax™ | TRUECURRENT®* |
| Dual Cool™ | MICROCOUPLER™ | SMART START™ | μSerDes™ |
| EcoSPARK® | MicroFET™ | Solutions for Your Success™ | UHC® |
| EfficientMax™ | MicroPak™ | SPM® | Ultra FRFET™ |
| ESBC™ | MicroPak2™ | STEALTH™ | UniFET™ |
| F [®] | MillerDrive™ | SuperFET® | VCX™ |
| Fairchild® | MotionMax™ | SuperSOT™-3 | VisualMax™ |
| Fairchild Semiconductor® | MotionGrid® | SuperSOT™-6 | VoltagePlus™ |
| FACT Quiet Series™ | MTi® | SuperSOT™-8 | XST™ |
| FACT® | MTx® | SupreMOS® | Xsens™ |
| FastvCore™ | MVN® | SyncFET™ | 仙童® |
| FETBench™ | mWSaver® | Sync-Lock™ | |
| FPS™ | OptoHiT™ | | |
| | OPTOLOGIC® | | |

* Trademarks of System General Corporation, used under license by Fairchild Semiconductor.

DISCLAIMER

FAIRCHILD SEMICONDUCTOR RESERVES THE RIGHT TO MAKE CHANGES WITHOUT FURTHER NOTICE TO ANY PRODUCTS HEREIN TO IMPROVE RELIABILITY, FUNCTION, OR DESIGN. TO OBTAIN THE LATEST, MOST UP-TO-DATE DATASHEET AND PRODUCT INFORMATION, VISIT OUR WEBSITE AT [HTTP://WWW.FAIRCHILDSEMI.COM](http://www.fairchildsemi.com). FAIRCHILD DOES NOT ASSUME ANY LIABILITY ARISING OUT OF THE APPLICATION OR USE OF ANY PRODUCT OR CIRCUIT DESCRIBED HEREIN; NEITHER DOES IT CONVEY ANY LICENSE UNDER ITS PATENT RIGHTS, NOR THE RIGHTS OF OTHERS. THESE SPECIFICATIONS DO NOT EXPAND THE TERMS OF FAIRCHILD'S WORLDWIDE TERMS AND CONDITIONS, SPECIFICALLY THE WARRANTY THEREIN, WHICH COVERS THESE PRODUCTS.

AUTHORIZED USE

Unless otherwise specified in this data sheet, this product is a standard commercial product and is not intended for use in applications that require extraordinary levels of quality and reliability. This product may not be used in the following applications, unless specifically approved in writing by a Fairchild officer: (1) automotive or other transportation, (2) military/aerospace, (3) any safety critical application – including life critical medical equipment – where the failure of the Fairchild product reasonably would be expected to result in personal injury, death or property damage. Customer's use of this product is subject to agreement of this Authorized Use policy. In the event of an unauthorized use of Fairchild's product, Fairchild accepts no liability in the event of product failure. In other respects, this product shall be subject to Fairchild's Worldwide Terms and Conditions of Sale, unless a separate agreement has been signed by both Parties.

ANTI-COUNTERFEITING POLICY

Fairchild Semiconductor Corporation's Anti-Counterfeiting Policy. Fairchild's Anti-Counterfeiting Policy is also stated on our external website, www.fairchildsemi.com, under Terms of Use

Counterfeiting of semiconductor parts is a growing problem in the industry. All manufacturers of semiconductor products are experiencing counterfeiting of their parts. Customers who inadvertently purchase counterfeit parts experience many problems such as loss of brand reputation, substandard performance, failed applications, and increased cost of production and manufacturing delays. Fairchild is taking strong measures to protect ourselves and our customers from the proliferation of counterfeit parts. Fairchild strongly encourages customers to purchase Fairchild parts either directly from Fairchild or from Authorized Fairchild Distributors who are listed by country on our web page cited above. Products customers buy either from Fairchild directly or from Authorized Fairchild Distributors are genuine parts, have full traceability, meet Fairchild's quality standards for handling and storage and provide access to Fairchild's full range of up-to-date technical and product information. Fairchild and our Authorized Distributors will stand behind all warranties and will appropriately address any warranty issues that may arise. Fairchild will not provide any warranty coverage or other assistance for parts bought from Unauthorized Sources. Fairchild is committed to combat this global problem and encourage our customers to do their part in stopping this practice by buying direct or from authorized distributors.

PRODUCT STATUS DEFINITIONS

Definition of Terms

Datasheet Identification	Product Status	Definition
Advance Information	Formative / In Design	Datasheet contains the design specifications for product development. Specifications may change in any manner without notice.
Preliminary	First Production	Datasheet contains preliminary data; supplementary data will be published at a later date. Fairchild Semiconductor reserves the right to make changes at any time without notice to improve design.
No Identification Needed	Full Production	Datasheet contains final specifications. Fairchild Semiconductor reserves the right to make changes at any time without notice to improve the design.
Obsolete	Not In Production	Datasheet contains specifications on a product that is discontinued by Fairchild Semiconductor. The datasheet is for reference information only.

Rev. I77

Mouser Electronics

Authorized Distributor

Click to View Pricing, Inventory, Delivery & Lifecycle Information:

[Fairchild Semiconductor:](#)

[FOD4116](#) [FOD4116SD](#) [FOD4116V](#) [FOD4116SDV](#) [FOD4116S](#) [FOD4116TV](#) [FOD4116SV](#)