



Is Now Part of



ON Semiconductor®

To learn more about ON Semiconductor, please visit our website at
www.onsemi.com

ON Semiconductor and the ON Semiconductor logo are trademarks of Semiconductor Components Industries, LLC dba ON Semiconductor or its subsidiaries in the United States and/or other countries. ON Semiconductor owns the rights to a number of patents, trademarks, copyrights, trade secrets, and other intellectual property. A listing of ON Semiconductor's product/patent coverage may be accessed at www.onsemi.com/site/pdf/Patent-Marking.pdf. ON Semiconductor reserves the right to make changes without further notice to any products herein. ON Semiconductor makes no warranty, representation or guarantee regarding the suitability of its products for any particular purpose, nor does ON Semiconductor assume any liability arising out of the application or use of any product or circuit, and specifically disclaims any and all liability, including without limitation special, consequential or incidental damages. Buyer is responsible for its products and applications using ON Semiconductor products, including compliance with all laws, regulations and safety requirements or standards, regardless of any support or applications information provided by ON Semiconductor. "Typical" parameters which may be provided in ON Semiconductor data sheets and/or specifications can and do vary in different applications and actual performance may vary over time. All operating parameters, including "Typicals" must be validated for each customer application by customer's technical experts. ON Semiconductor does not convey any license under its patent rights nor the rights of others. ON Semiconductor products are not designed, intended, or authorized for use as a critical component in life support systems or any FDA Class 3 medical devices or medical devices with a same or similar classification in a foreign jurisdiction or any devices intended for implantation in the human body. Should Buyer purchase or use ON Semiconductor products for any such unintended or unauthorized application, Buyer shall indemnify and hold ON Semiconductor and its officers, employees, subsidiaries, affiliates, and distributors harmless against all claims, costs, damages, and expenses, and reasonable attorney fees arising out of, directly or indirectly, any claim of personal injury or death associated with such unintended or unauthorized use, even if such claim alleges that ON Semiconductor was negligent regarding the design or manufacture of the part. ON Semiconductor is an Equal Opportunity/Affirmative Action Employer. This literature is subject to all applicable copyright laws and is not for resale in any manner.



HCPL0452, HCPL0453, HCPL0500, HCPL0501, HCPL0530, HCPL0531, HCPL0534 High Speed Transistor Optocouplers

Single Channel: HCPL0452 HCPL0453 HCPL0500 HCPL0501
Dual Channel: HCPL0530 HCPL0531 HCPL0534

Features

- High speed – 1 MBit/s
- 15kV/ μ s minimum common mode transient immunity at $V_{CM} = 1500V$ (HCPL0453/0534)
- Open collector output
- Guaranteed performance over temperature: 0°C to 70°C
- U.L. recognized (File # E90700)
- VDE0884 recognized (file#136616)
 - approval pending for HCPL0530/0531/0453
 - ordering option V, e.g., HCPL0500V
- BSI recognized (file# 8661, 8662)
 - HCPL0452/0500/0501 only

Applications

- Line receivers
- Pulse transformer replacement
- Output interface to CMOS-LSTTL-TTL
- Wide bandwidth analog coupling

Description

The HCPL05XX, and HCPL04XX optocouplers consist of an AlGaAs LED optically coupled to a high speed photodetector transistor housed in a compact 8-pin small out-line package.

A separate connection for the bias of the photodiode improves the speed by several orders of magnitude over conventional phototransistor optocouplers by reducing the base-collector capacitance of the input transistor. The HCPL04XX devices do not have the base bonded out to a lead for additional noise margin. The HCPL053X devices have two channels per package for optimum mounting density.

Truth Table (positive Logic)

LED	V _o
ON	LOW
OFF	HIGH

Schematics

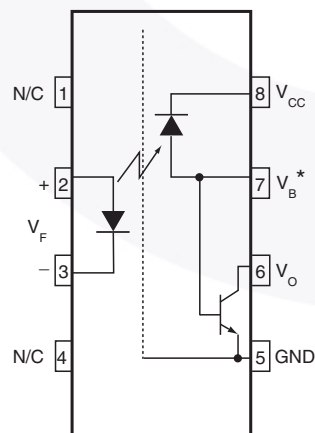

HCPL0500, HCPL0501
*BASE NOT CONNECTED
FOR HCPL0452, HCPL0453

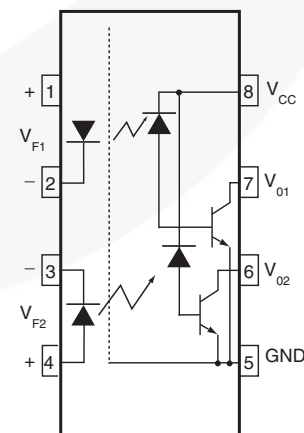

HCPL0530/HCPL0531/HCPL0534

Absolute Maximum Ratings ($T_A = 25^\circ\text{C}$ unless otherwise specified)

Stresses exceeding the absolute maximum ratings may damage the device. The device may not function or be operable above the recommended operating conditions and stressing the parts to these levels is not recommended. In addition, extended exposure to stresses above the recommended operating conditions may affect device reliability. The absolute maximum ratings are stress ratings only.

Symbol	Parameter	Value	Units
T_{STG}	Storage Temperature	-40 to +125	$^\circ\text{C}$
T_{OPR}	Operating Temperature	-40 to +85	$^\circ\text{C}$
	Reflow Temperature Profile (Refer to page 11)		
EMITTER			
I_F (avg)	DC/Average Forward Input Current	25	mA
I_F (pk)	Peak Forward Input Current (50% duty cycle, 1ms P.W.)	50	mA
I_F (trans)	Peak Transient Input Current - ($\leq 1\mu\text{s}$ P.W., 300 pps)	1.0	A
V_R	Reverse Input Voltage	5	V
P_D	Input Power Dissipation	45	mW
DETECTOR			
I_O (avg)	Average Output Current (Pin 6)	8	mA
I_O (pk)	Peak Output Current	16	mA
V_{EBR}	Emitter-Base Reverse Voltage (HCPL0500/HCPL0501 only)	5	V
V_{CC}	Supply Voltage	-0.5 to 30	V
V_O	Output Voltage	-0.5 to 20	V
I_B	Base Current (HCPL0500/HCPL0501 only)	5	mA
P_D	Output power dissipation	100	mW

Electrical Characteristics ($T_A = 0$ to 70°C unless otherwise specified)

Individual Component Characteristics

Symbol	Parameter	Test Conditions	Device	Min.	Typ.*	Max.	Unit
EMITTER							
V_F	Input Forward Voltage	$I_F = 16\text{mA}, T_A = 25^\circ\text{C}$	All		1.45	1.7	V
		$I_F = 16\text{mA}$				1.8	
BV_R	Input Reverse Breakdown Voltage	$I_R = 10\mu\text{A}$	All	5.0			V
$\Delta V_F / \Delta T_A$	Temperature Coefficient of Forward Voltage	$I_F = 16\text{mA}$	All		-1.6		mV/ $^\circ\text{C}$
DETECTOR							
I_{OH}	Logic High Output Current	$I_F = 0\text{mA}, V_O = V_{CC} = 5.5\text{V}, T_A = 25^\circ\text{C}$	All		0.001	0.5	μA
		$I_F = 0\text{mA}, V_O = V_{CC} = 15\text{V}, T_A = 25^\circ\text{C}$	All		0.005	1	
		$I_F = 0\text{mA}, V_O = V_{CC} = 15\text{V}$	All			50	
I_{CCL}	Logic Low Supply Current	$I_F = 16\text{mA}, V_O = \text{Open}, V_{CC} = 15\text{V}$	HCPL0452/3/0500/1		120	200	μA
			HCPL0530/1/4			400	
I_{CCH}	Logic High Supply Current	$I_F = 0\text{mA}, V_O = \text{Open}, V_{CC} = 15\text{V}, T_A = 25^\circ\text{C}$	All		0.01	1	μA
			HCPL0452/3/0500/1			2	
			HCPL0530/1/4			4	

Transfer Characteristics

Symbol	Parameter	Test Conditions	Device	Min.	Typ.*	Max.	Unit
COUPLED							
CTR	Current Transfer Ratio (Note 1)	$I_F = 16\text{mA}, V_O = 0.4\text{V}, V_{CC} = 4.5\text{V}, T_A = 25^\circ\text{C}$	HCPL0500/0530	7	27	50	%
			HCPL0452/3	19	27	50	
			HCPL0501/0531				
		$I_F = 16\text{mA}, V_O = 0.5\text{V}, V_{CC} = 4.5\text{V}$	HCPL0500	5	30		
			HCPL0452/3	15	30		
V_{OL}	Logic Low Output Voltage	$I_F = 16\text{mA}, I_O = 1.1\text{mA}, V_{CC} = 4.5\text{V}, T_A = 25^\circ\text{C}$	HCPL0500		0.18	0.4	V
			HCPL0530			0.5	
		$I_F = 16\text{mA}, I_O = 3\text{mA}, V_{CC} = 4.5\text{V}, T_A = 25^\circ\text{C}$	HCPL0452/3		0.25	0.4	
			HCPL0501/0531/4				
		$I_F = 16\text{mA}, I_O = 0.8\text{mA}, V_{CC} = 4.5\text{V}$	HCPL0500		0.13	0.5	
			HCPL0530				
		$I_F = 16\text{mA}, I_O = 2.4\text{mA}, V_{CC} = 4.5\text{V}$	HCPL0452/3		0.23	0.5	
			HCPL0501/0531/4				

 *All typicals at $T_A = 25^\circ\text{C}$

Electrical Characteristics (Continued) ($T_A = 0$ to 70°C unless otherwise specified)

Switching Characteristics $T_{V_{CC}} = 5\text{V}$

Symbol	Parameter	Test Conditions	Device	Min.	Typ.*	Max.	Unit
T_{PHL}	Propagation Delay Time to Logic LOW	$T_A = 25^\circ\text{C}$, $R_L = 4.1\text{k}\Omega$, $I_F = 16\text{mA}$ (Note 2) (Fig. 9)	HCPL0500/0530		0.45	1.5	μs
		$R_L = 1.9\text{k}\Omega$, $I_F = 16\text{mA}$, $T_A = 25^\circ\text{C}$ (Note 3) (Fig. 9)	HCPL0452/3		0.45	0.8	
			HCPL0501/0531/4				
		$R_L = 4.1\text{k}\Omega$, $I_F = 16\text{mA}$ (Note 2) (Fig. 9)	HCPL0500/0530				
$R_L = 1.9\text{k}\Omega$, $I_F = 16\text{mA}$ (Note 3) (Fig. 9)	HCPL0452/3				1.0		
	HCPL0501/0531/4						
T_{PLH}	Propagation Delay Time to Logic HIGH	$T_A = 25^\circ\text{C}$, $R_L = 4.1\text{k}\Omega$, $I_F = 16\text{mA}$ (Note 2) (Fig. 9)	HCPL0500/0530		0.5	1.5	μs
		$R_L = 1.9\text{k}\Omega$, $I_F = 16\text{mA}$, $T_A = 25^\circ\text{C}$ (Note 3) (Fig. 9)	HCPL0452/3		0.3	0.8	
			HCPL0501/0531/4				
		$R_L = 4.1\text{k}\Omega$, $I_F = 16\text{mA}$ (Note 2) (Fig. 9)	HCPL0500/0530				
$R_L = 1.9\text{k}\Omega$, $I_F = 16\text{mA}$ (Note 3) (Fig. 9)	HCPL0452/3				1.0		
	HCPL0501/0531/4						
ICM_{HI}	Common Mode Transient Immunity at Logic HIGH	$I_F = 0\text{mA}$, $V_{CM} = 10\text{V}_{P-P}$, $R_L = 4.1\text{k}\Omega$, $T_A = 25^\circ\text{C}$ (Note 4) (Fig. 10)	HCPL0500	1,000	10,000		$\text{V}/\mu\text{s}$
			HCPL0530				
		$I_F = 0\text{mA}$, $V_{CM} = 10\text{V}_{P-P}$, $R_L = 1.9\text{k}\Omega$, $T_A = 25^\circ\text{C}$, (Note 4) (Fig. 10)	HCPL0452	1,000	10,000		
			HCPL0501/31				
HCPL0534	15,000	40,000					
$I_F = 16\text{mA}$, $V_{CM} = 1500\text{V}_{P-P}$, $R_L = 1.9\Omega$, $T_A = 25^\circ\text{C}$ (Note 4) (Fig. 10)	HCPL0453	15,000	40,000				
ICM_{LI}	Common Mode Transient Immunity at Logic LOW	$I_F = 16\text{mA}$, $V_{CM} = 10\text{V}_{P-P}$, $R_L = 4.1\text{k}\Omega$, $T_A = 25^\circ\text{C}$ (Note 4) (Fig. 10)	HCPL0500	1,000	10,000	$\text{V}/\mu\text{s}$	
			HCPL0530				
		$I_F = 16\text{mA}$, $V_{CM} = 10\text{V}_{P-P}$, $R_L = 1.9\text{k}\Omega$ (Note 4) (Fig. 10)	HCPL0452	1,000	10,000		
			HCPL0501/31				
HCPL0534	15,000	40,000					
$I_F = 16\text{mA}$, $T_A = 25^\circ\text{C}$, $V_{CM} = 1500\text{V}_{P-P}$, $C_L = 15\text{pF}$ (Note 4) (Fig. 10)	HCPL0453	15,000	40,000				

Isolation Characteristics

Symbol	Characteristics	Test Conditions	Min.	Typ.*	Max.	Unit
V_{ISO}	Input-Output Isolation Voltage	$f = 60\text{Hz}$, $t = 1.0\text{min.}$, $I_{I-O} \leq 2\mu\text{A}$ (Note 5, 6)	2500			$V_{ac_{RMS}}$
R_{ISO}	Isolation Resistance	$V_{I-O} = 500\text{V}$ (Note 5)	10^{11}			
C_{ISO}	Isolation Capacitance	$V_{I-O} = 0$, $f = 1.0\text{MHz}$ (Note 5)		0.2		pF

 *All typicals at $T_A = 25^\circ\text{C}$

Notes

1. Current Transfer Ratio is designed as a ratio of output collector current, I_O , to the forward LED input current, I_F times 100%.
2. The 4.1 k Ω load represents 1 LSTTL unit load of 0.36 mA and 6.1k Ω pull-up resistor.
3. The 1.9 k Ω load represents 1 TTL unit load of 1.6 mA and 5.6 k Ω pull-up resistor.
4. Common mode transient immunity in logic high level is the maximum tolerable (positive) dV_{cm}/dt on the leading edge of the common mode pulse signal V_{CM} , to assure that the output will remain in a logic high state (i.e., $V_O > 2.0$ V). Common mode transient immunity in logic low level is the maximum tolerable (negative) dV_{cm}/dt on the trailing edge of the common mode pulse signal, V_{CM} , to assure that the output will remain in a logic low state (i.e., $V_O < 0.8$ V).
5. Device is considered a two terminal device: Pins 1, 2, 3 and 4 are shorted together and Pins 5, 6, 7 and 8 are shorted together.
6. 2500 VAC RMS for 1 minute duration is equivalent to 3000 VAC RMS for 1 second duration.

Typical Performance Curves

Fig. 1 Normalized CTR vs. Forward Current

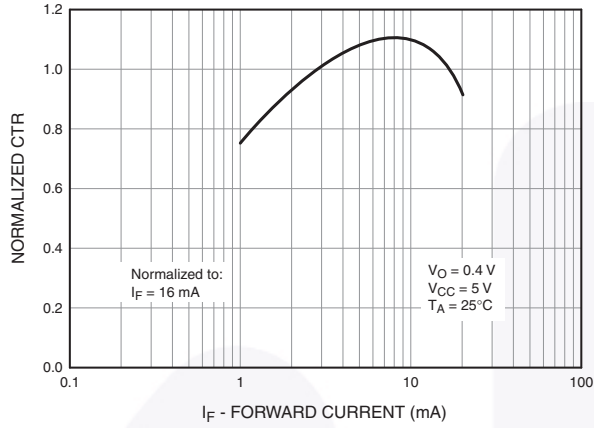

Fig. 2 Normalized CTR vs. Temperature

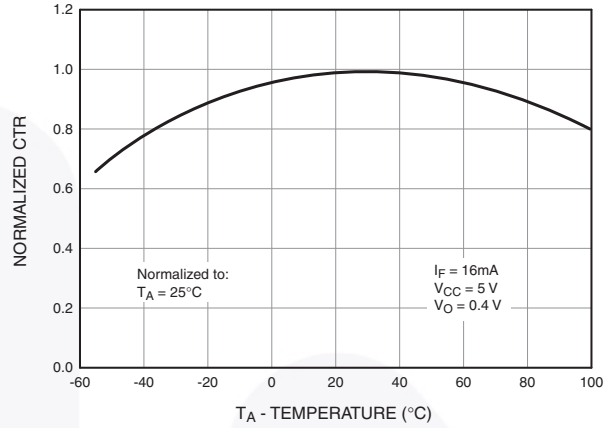

Fig. 3 Output Current vs. Output Voltage

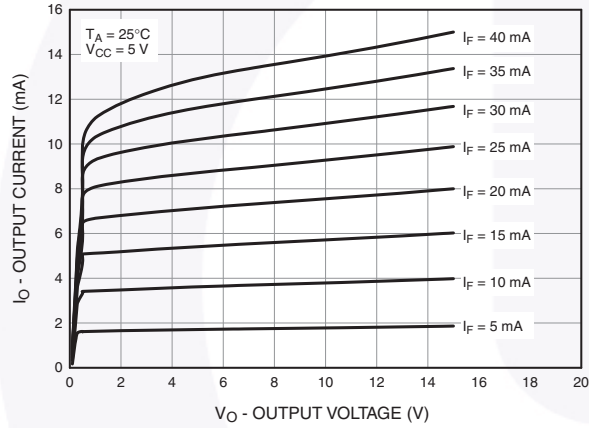

Fig. 4 Logic High Output Current vs. Temperature

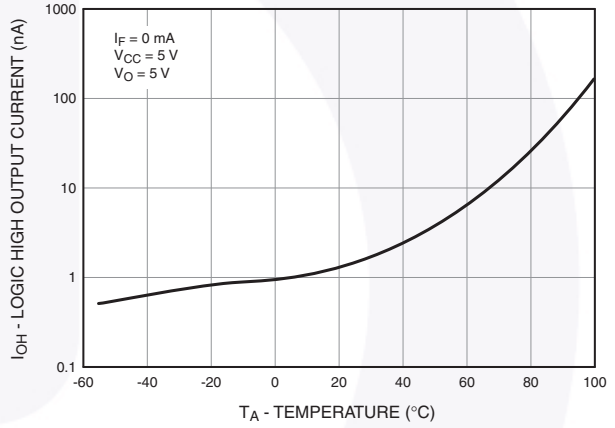

Fig. 5 Propagation Delay vs. Temperature

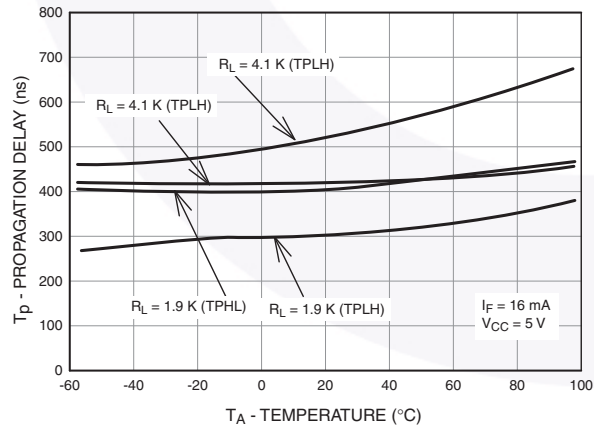
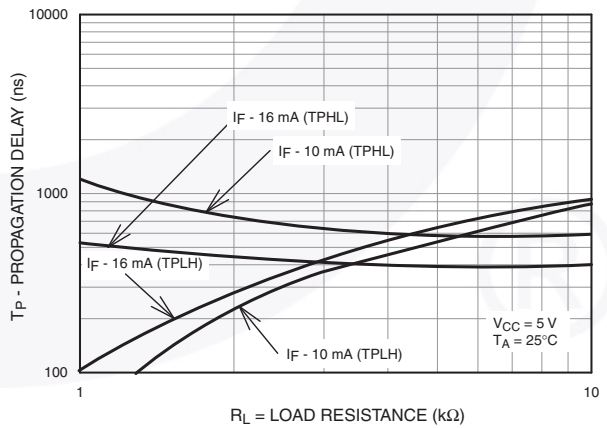
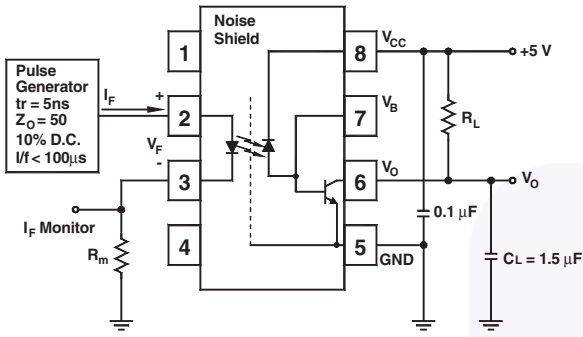
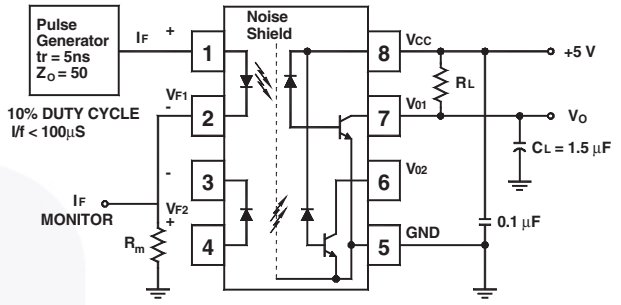

Fig. 6 Propagation Delay vs. Load Resistance





Test Circuit for HCPL0452, HCPL0453, HCPL0500 and HCPL0501



Test Circuit for HCPL0530, HCPL0531 and HCPL0534

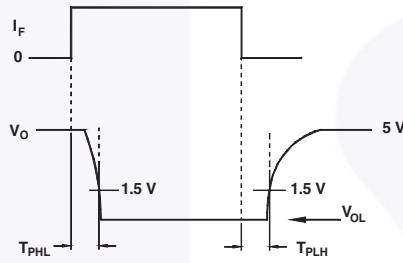
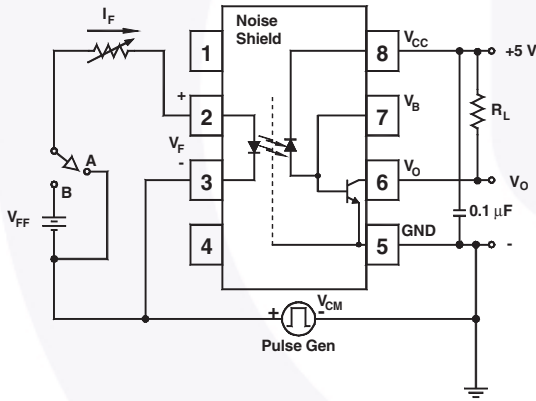
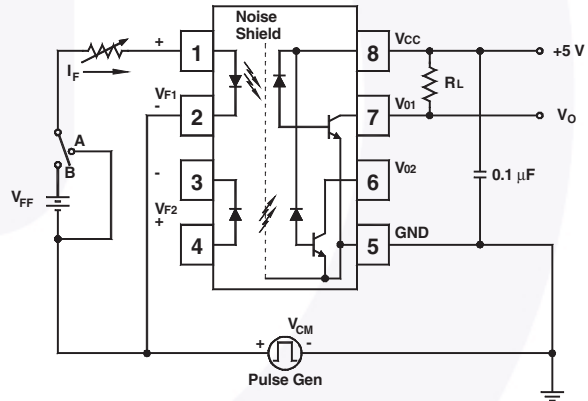

Fig. 7 Switching Time Test Circuit



Test Circuit for HCPL0452, HCPL0453, HCPL0500 and HCPL0501



Test Circuit for HCPL0530, HCPL0531 and HCPL0534

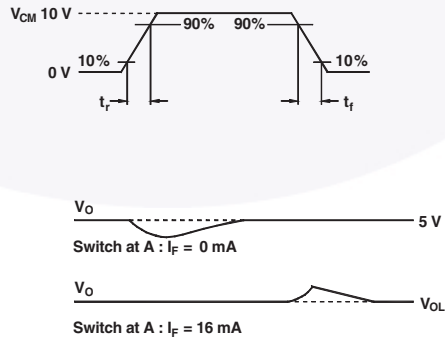
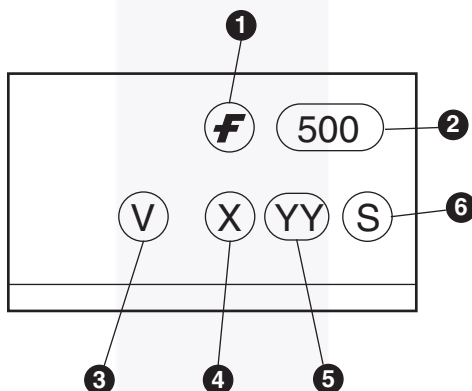

Fig. 8 Common Mode Immunity Test Circuit

Ordering Information

Option	Order Entry Identifier	Description
V	V	VDE 0884 (approval pending for HCPL0530, HCPL0531 & HCPL0534)
R2	R2	Tape and reel (2500 units per reel)
R2V	R2V	VDE 0884 (approval pending for HCPL0530, HCPL0531 & HCPL0534), Tape and reel (2500 units per reel)

Marking Information



Definitions	
1	Fairchild logo
2	Device number
3	VDE mark (Note: Only appears on parts ordered with VDE option – See order entry table)
4	One digit year code, e.g., '3'
5	Two digit work week ranging from '01' to '53'
6	Assembly package code

Carrier Tape Specifications

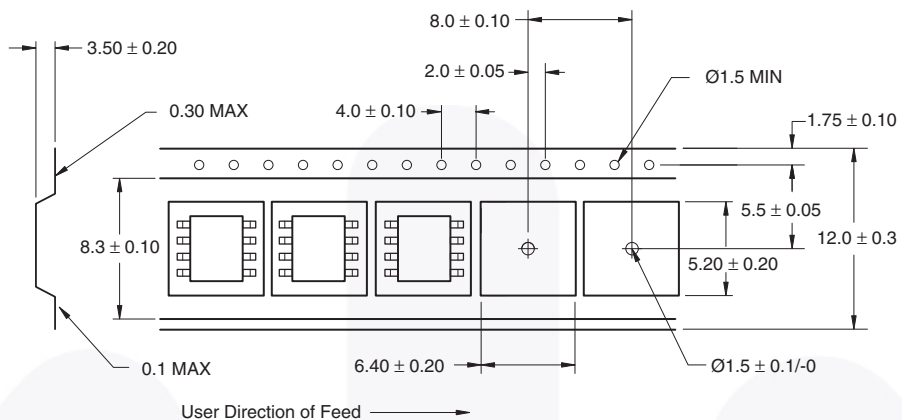

Reflow Profile

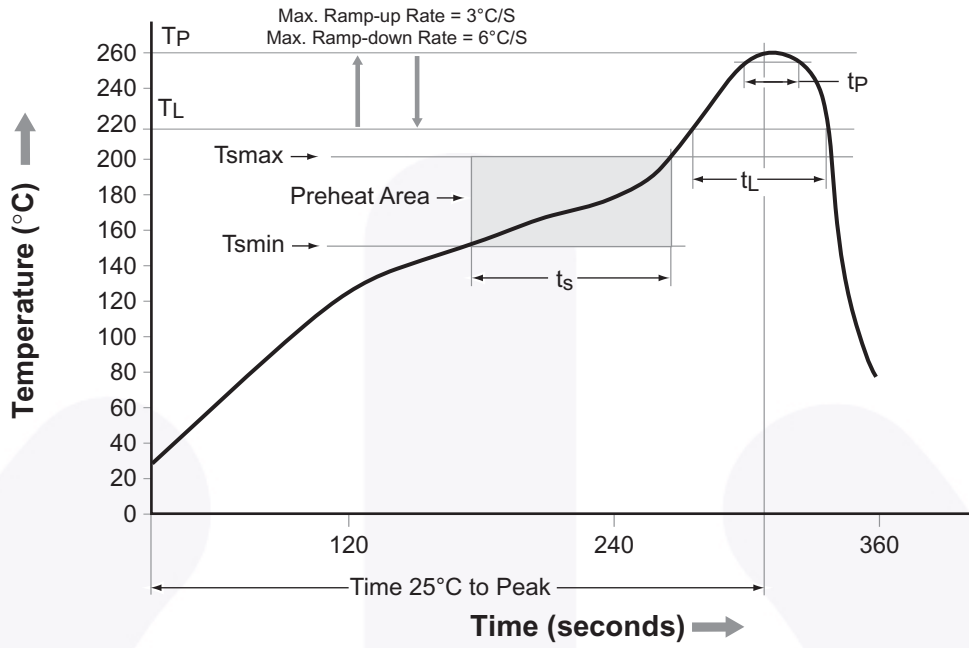

Profile Feature	Pb-Free Assembly Profile
Temperature Min. (T_{smin})	150°C
Temperature Max. (T_{smax})	200°C
Time (t_s) from (T_{smin} to T_{smax})	60–120 seconds
Ramp-up Rate (t_L to t_p)	3°C/second max.
Liquidous Temperature (T_L)	217°C
Time (t_L) Maintained Above (T_L)	60–150 seconds
Peak Body Package Temperature	260°C +0°C / -5°C
Time (t_p) within 5°C of 260°C	30 seconds
Ramp-down Rate (T_P to T_L)	6°C/second max.
Time 25°C to Peak Temperature	8 minutes max.



NOTES:

- A) NO STANDARD APPLIES TO THIS PACKAGE
- B) ALL DIMENSIONS ARE IN MILLIMETERS.
- C) DIMENSIONS DO NOT INCLUDE MOLD FLASH OR BURRS.
- D) LANDPATTERN STANDARD: SOIC127P600X175-8M.
- E) DRAWING FILENAME: MKT-M08Erev5





TRADEMARKS

The following includes registered and unregistered trademarks and service marks, owned by Fairchild Semiconductor and/or its global subsidiaries, and is not intended to be an exhaustive list of all such trademarks.

- | | | | |
|--------------------------|--|---------------------------------------|------------------|
| AccuPower™ | F-PFS™ | OPTOPLANAR® | SYSTEM GENERAL® |
| AttitudeEngine™ | FRFET® | Power Supply WebDesigner™ | TinyBoost® |
| Awinda® | Global Power Resource SM | PowerTrench® | TinyBuck® |
| AX-CAP®* | GreenBridge™ | PowerXS™ | TinyCalc™ |
| BitSiC™ | Green FPS™ | Programmable Active Droop™ | TinyLogic® |
| Build it Now™ | Green FPS™ e-Series™ | QFET® | TINYOPTO™ |
| CorePLUS™ | Gmax™ | QS™ | TinyPower™ |
| CorePOWER™ | GTO™ | Quiet Series™ | TinyPWM™ |
| CROSSVOL™ | IntelliMAX™ | RapidConfigure™ | TinyWire™ |
| CTL™ | ISOPLANAR™ | Saving our world, 1mW/W/kW at a time™ | TranSiC™ |
| Current Transfer Logic™ | Making Small Speakers Sound Louder and Better™ | SignalWise™ | TriFault Detect™ |
| DEUXPEED® | MegaBuck™ | SmartMax™ | TRUECURRENT®* |
| Dual Cool™ | MICROCOUPLER™ | SMART START™ | μSerDes™ |
| EcoSPARK® | MicroFET™ | Solutions for Your Success™ | UHC® |
| EfficientMax™ | MicroPak™ | SPM® | Ultra FRFET™ |
| ESBC™ | MicroPak2™ | STEALTH™ | UniFET™ |
| F [®] | MillerDrive™ | SuperFET® | VCX™ |
| Fairchild® | MotionMax™ | SuperSOT™-3 | VisualMax™ |
| Fairchild Semiconductor® | MotionGrid® | SuperSOT™-6 | VoltagePlus™ |
| FACT Quiet Series™ | MTi® | SuperSOT™-8 | XST™ |
| FACT® | MTx® | SupreMOS® | Xsens™ |
| FastvCore™ | MVN® | SyncFET™ | 仙童® |
| FETBench™ | mWSaver® | Sync-Lock™ | |
| FPS™ | OptoHiT™ | | |
| | OPTOLOGIC® | | |

* Trademarks of System General Corporation, used under license by Fairchild Semiconductor.

DISCLAIMER

FAIRCHILD SEMICONDUCTOR RESERVES THE RIGHT TO MAKE CHANGES WITHOUT FURTHER NOTICE TO ANY PRODUCTS HEREIN TO IMPROVE RELIABILITY, FUNCTION, OR DESIGN. TO OBTAIN THE LATEST, MOST UP-TO-DATE DATASHEET AND PRODUCT INFORMATION, VISIT OUR WEBSITE AT [HTTP://WWW.FAIRCHILDSEMI.COM](http://www.fairchildsemi.com). FAIRCHILD DOES NOT ASSUME ANY LIABILITY ARISING OUT OF THE APPLICATION OR USE OF ANY PRODUCT OR CIRCUIT DESCRIBED HEREIN; NEITHER DOES IT CONVEY ANY LICENSE UNDER ITS PATENT RIGHTS, NOR THE RIGHTS OF OTHERS. THESE SPECIFICATIONS DO NOT EXPAND THE TERMS OF FAIRCHILD'S WORLDWIDE TERMS AND CONDITIONS, SPECIFICALLY THE WARRANTY THEREIN, WHICH COVERS THESE PRODUCTS.

AUTHORIZED USE

Unless otherwise specified in this data sheet, this product is a standard commercial product and is not intended for use in applications that require extraordinary levels of quality and reliability. This product may not be used in the following applications, unless specifically approved in writing by a Fairchild officer: (1) automotive or other transportation, (2) military/aerospace, (3) any safety critical application – including life critical medical equipment – where the failure of the Fairchild product reasonably would be expected to result in personal injury, death or property damage. Customer's use of this product is subject to agreement of this Authorized Use policy. In the event of an unauthorized use of Fairchild's product, Fairchild accepts no liability in the event of product failure. In other respects, this product shall be subject to Fairchild's Worldwide Terms and Conditions of Sale, unless a separate agreement has been signed by both Parties.

ANTI-COUNTERFEITING POLICY

Fairchild Semiconductor Corporation's Anti-Counterfeiting Policy. Fairchild's Anti-Counterfeiting Policy is also stated on our external website, www.fairchildsemi.com, under Terms of Use

Counterfeiting of semiconductor parts is a growing problem in the industry. All manufacturers of semiconductor products are experiencing counterfeiting of their parts. Customers who inadvertently purchase counterfeit parts experience many problems such as loss of brand reputation, substandard performance, failed applications, and increased cost of production and manufacturing delays. Fairchild is taking strong measures to protect ourselves and our customers from the proliferation of counterfeit parts. Fairchild strongly encourages customers to purchase Fairchild parts either directly from Fairchild or from Authorized Fairchild Distributors who are listed by country on our web page cited above. Products customers buy either from Fairchild directly or from Authorized Fairchild Distributors are genuine parts, have full traceability, meet Fairchild's quality standards for handling and storage and provide access to Fairchild's full range of up-to-date technical and product information. Fairchild and our Authorized Distributors will stand behind all warranties and will appropriately address any warranty issues that may arise. Fairchild will not provide any warranty coverage or other assistance for parts bought from Unauthorized Sources. Fairchild is committed to combat this global problem and encourage our customers to do their part in stopping this practice by buying direct or from authorized distributors.

PRODUCT STATUS DEFINITIONS

Definition of Terms

Datasheet Identification	Product Status	Definition
Advance Information	Formative / In Design	Datasheet contains the design specifications for product development. Specifications may change in any manner without notice.
Preliminary	First Production	Datasheet contains preliminary data; supplementary data will be published at a later date. Fairchild Semiconductor reserves the right to make changes at any time without notice to improve design.
No Identification Needed	Full Production	Datasheet contains final specifications. Fairchild Semiconductor reserves the right to make changes at any time without notice to improve the design.
Obsolete	Not In Production	Datasheet contains specifications on a product that is discontinued by Fairchild Semiconductor. The datasheet is for reference information only.

Mouser Electronics

Authorized Distributor

Click to View Pricing, Inventory, Delivery & Lifecycle Information:

[Fairchild Semiconductor:](#)

[HCPL0453](#) [HCPL0453R2](#)