

LM556/NE556 Dual Timer

Features

- Replaces Two LM555/NE555 Timers
- Operates in Both Astable And Monostable Modes
- High Output Current
- TTL Compatible
- Timing From Microsecond To Hours
- Adjustable Duty Cycle
- Temperature Stability Of 0.005% Per °C

Applications

- Precision Timing
- Pulse Shaping
- Pulse Width Modulation
- Frequency Division
- Traffic Light Control
- Sequential Timing
- Pulse Generator
- Time Delay Generator
- Touch Tone Encoder
- Tone Burst Generator

Description

The LM556/NE556 series dual monolithic timing circuits are a highly stable controller capable of producing accurate time delays or oscillation. The LM556/NE556 is a dual LM555. Timing is provided an external resistor and capacitor for each timing function. The two timers operate independently of each other, sharing only VCC and ground. The circuits may be triggered and reset on falling waveforms. The output structures may sink or source 200mA.

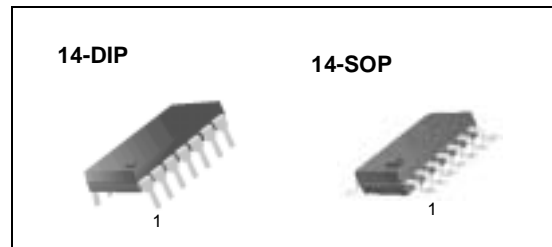

Internal Block Diagram

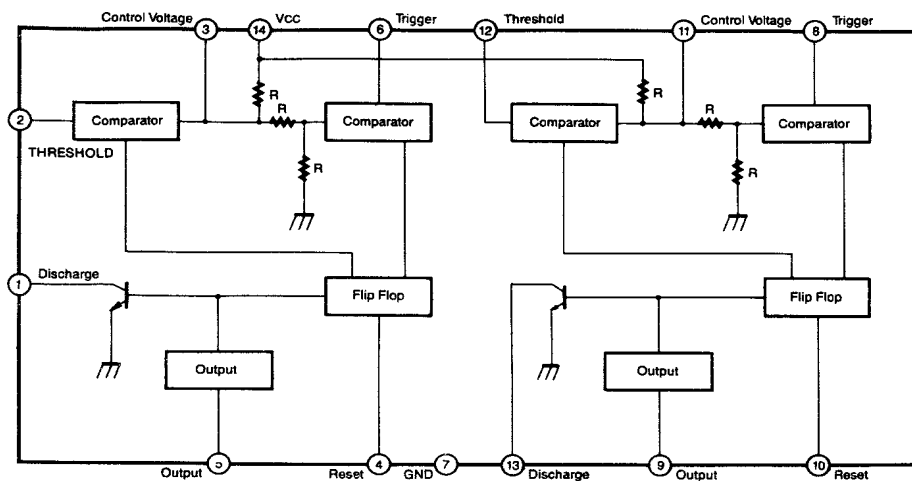

Ordering Information

Product Number	Package	Operating Temperature
LM556CN	14-DIP	0 ~ + 70°C
LM556CM	14-SOP	
NE556N	14-DIP	
NE556M	14-SOP	

Absolute Maximum Ratings (T_A = 25°C)

Parameter	Symbol	Value	Unit
Supply Voltage	V _{CC}	16	V
Lead Temperature (soldering 10sec)	T _{LEAD}	300	°C
Power Dissipation	P _D	600	mW
Operating Temperature Range LM556/NE556	T _{OPR}	0 ~ + 70	°C
Storage Temperature Range	T _{STG}	- 65 ~ + 150	°C

Electrical Characteristics

(TA = 25°C, VCC = 5 ~ 15V, unless otherwise specified)

Parameter	Symbol	Conditions	Min.	Typ.	Max.	Units
Supply Voltage	VCC	-	4.5	-	16	V
Supply Current *1(two timers) (low state)	ICC	VCC = 5V, RL = ∞ VCC = 15V, RL = ∞	-	5 16	12 30	mA mA
Timing Error *2(monostable) Initial Accuracy Drift with Temperature Drift with Supply Voltage	ACCUR Δt/ΔT Δt/ΔVCC	RA = 2KΩ to 100KΩ C = 0.1μF T = 1.1RC	-	0.75 50 0.1	-	% ppm/°C %/V
Control Voltage	VC	VCC = 15V	9.0	10.0	11.0	V
		VCC = 5V	2.6	3.33	4.0	V
Threshold Voltage	VTH	VCC = 15V	8.8	10.0	11.2	V
		VCC = 5V	2.4	3.33	4.2	V
Threshold Current*3	ITH	-	-	30	250	nA
Trigger Voltage	VTR	VCC = 15V	4.5	5.0	5.6	V
		VCC = 5V	1.1	1.6	2.2	V
Trigger Current	ITR	VTR = 0V	-	0.01	2.0	μA
Reset Voltage*5	VRST	-	0.4	0.6	1.0	V
Reset Current	IRST	-	-	0.03	0.6	mA
Low Output Voltage	VOL	VCC = 15V ISINK = 10mA ISINK = 50mA ISINK = 100mA ISINK = 200mA	-	0.1 0.4 2.0 2.5	0.25 0.75 3.2	V
		VCC = 5V ISINK = 8mA ISINK = 5mA	-	0.25 0.15	0.35 0.25	V
High Output Voltage	VOH	VCC = 15V ISOURCE = 200mA ISOURCE = 100mA	12.75	12.5 13.3	-	V
		VCC = 5V ISOURCE = 100mA	2.75	3.3	-	V
Rise Time of Output	tR	-	-	100	300	ns
Fall Time of Output	tF	-	-	100	300	ns
Discharge Leakage Current	ILKG	-	-	10	100	nA
Matching Characteristics*4 Initial Accuracy Drift with Temperature Drift with Supply Voltage	ACCUR Δt/ΔT Δt/ΔVCC	-	-	1.0 10 0.2	2.0 - 0.5	% ppm/°C %/V
Timing Error (astable)*2 Initial Accuracy Drift with Temperature Drift with Supply Voltage	ACCUR Δt/ΔT Δt/ΔVCC	VCC = 15V RA, RB = 1KΩ to 100KΩ C = 0.1μF	-	2.25 150 0.3	-	% ppm/°C %/V

Notes:

*1. Supply current when output is high is typically 1.0mA less at VCC = 5V

*2. Tested at VCC = 5V and VCC = 15V

 *3. This will determine the maximum value of RA + RB for 15V operation.
 The maximum total R = 20MΩ, and for 5V operation the maximum total R = 6.6MΩ.

*4. Matching characteristics refer to the difference between performance characteristics of each timer section in the monostable mode.

*5. As reset voltage lowers, timing is inhibited and then the output goes low.

Important statement:

Huaguan Semiconductor Co,Ltd. reserves the right to change the products and services provided without notice. Customers should obtain the latest relevant information before ordering, and verify the timeliness and accuracy of this information.

Customers are responsible for complying with safety standards and taking safety measures when using our products for system design and machine manufacturing to avoid potential risks that may result in personal injury or property damage.

Our products are not licensed for applications in life support, military, aerospace, etc., so we do not bear the consequences of the application of these products in these fields.

Our documentation is only permitted to be copied without any tampering with the content, so we do not accept any responsibility or liability for the altered documents.