

# International Rectifier

## IR Rectifier

INSULATED GATE BIPOLAR TRANSISTOR WITH HYPERFAST DIODE

PD - 95614A

# IRG4BC30FD1PbF

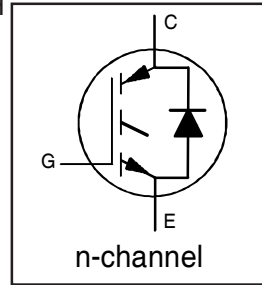
Fast CoPack IGBT

### Features

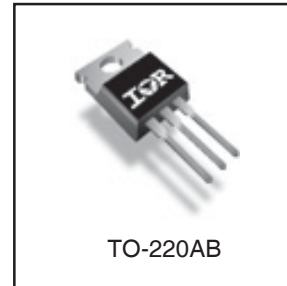
- Fast: optimized for medium operating frequencies (1-5 kHz in hard switching, >20kHz in resonant mode).
- Generation 4 IGBT design provides tighter parameter distribution and higher efficiency than Generation 3.
- IGBT co-packaged with Hyperfast FRED diodes for ultra low recovery characteristics.
- Industry standard TO-220AB package.
- Lead-Free

### Benefits

- Generation 4 IGBT's offer highest efficiency available.
- IGBT's optimized for specific application conditions.
- FRED diodes optimized for performance with IGBT's. Minimized recovery characteristics require less / no snubbing.



$V_{CES} = 600V$
$V_{CE(on)} \text{ typ.} = 1.59V$
@ $V_{GE} = 15V, I_C = 17A$



### Absolute Maximum Ratings

	Parameter	Max.	Units
$V_{CES}$	Collector-to-Emitter Voltage	600	V
$I_C @ T_C = 25^\circ C$	Continuous Collector Current	31	A
$I_C @ T_C = 100^\circ C$	Continuous Collector Current	17	
$I_{CM}$	Pulse Collector Current (Ref.Fig.C.T.5) ①	124	
$I_{LM}$	Clamped Inductive Load current ②	124	
$I_F @ T_C = 100^\circ C$	Diode Continuous Forward Current	8	
$I_{FM}$	Diode Maximum Forward Current	16	
$V_{GE}$	Gate-to-Emitter Voltage	$\pm 20$	V
$P_D @ T_C = 25^\circ C$	Maximum Power Dissipation	100	W
$P_D @ T_C = 100^\circ C$	Maximum Power Dissipation	42	
$T_J$	Operating Junction and	-55 to +150	°C
$T_{STG}$	Storage Temperature Range		
	Storage Temperature Range, for 10 sec.		
	Mounting Torque, 6-32 or M3 Screw	10 lbf-in (1.1 N-m)	

### Thermal / Mechanical Characteristics

	Parameter	Min.	Typ.	Max.	Units
$R_{\theta JC}$	Junction-to-Case- IGBT	—	—	1.2	°C/W
$R_{\theta JC}$	Junction-to-Case- Diode	—	—	2.0	
$R_{\theta CS}$	Case-to-Sink, flat, greased surface	—	0.50	—	
$R_{\theta JA}$	Junction-to-Ambient, typical socket mount	—	—	80	
Wt	Weight	—	2.0 (0.07)	—	g (oz.)

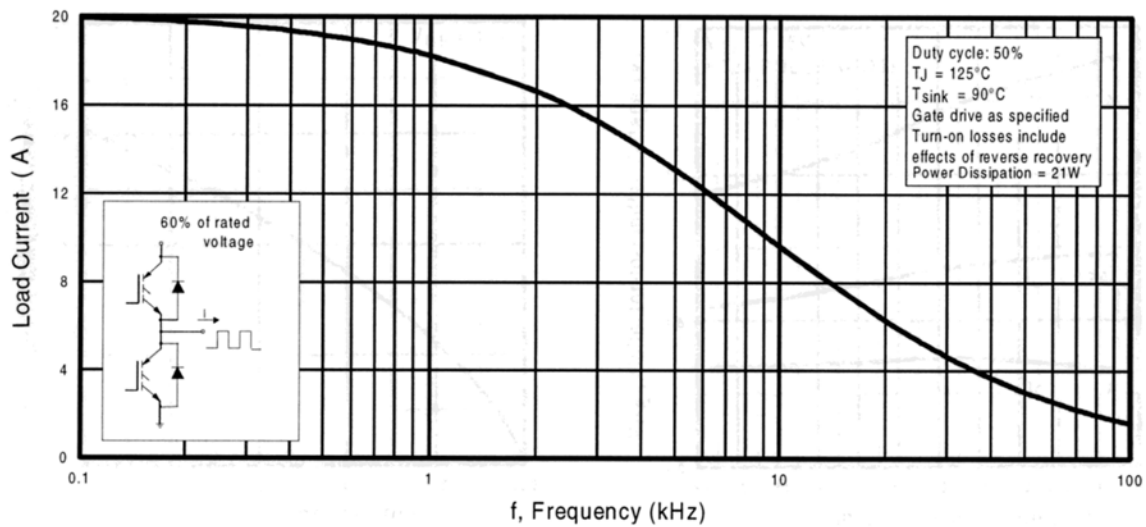
# IRG4BC30FD1PbF

## Electrical Characteristics @ $T_J = 25^\circ\text{C}$ (unless otherwise specified)

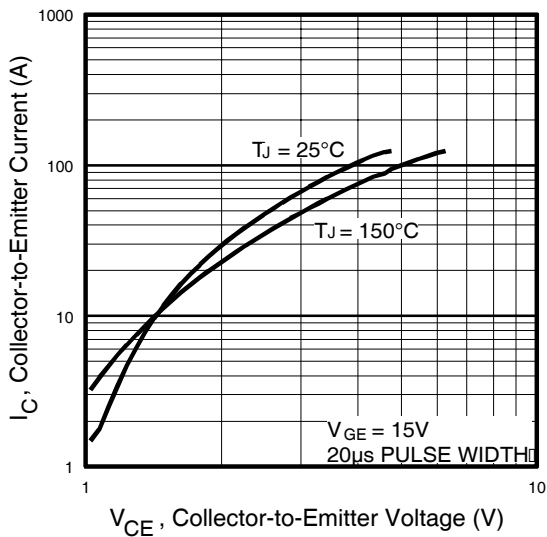
	Parameter	Min.	Typ.	Max.	Units	Conditions
$V_{(BR)CES}$	Collector-to-Emitter Breakdown Voltage ③	600	—	—	V	$V_{GE} = 0V, I_C = 250\mu A$
$\Delta V_{(BR)CES}/\Delta T_J$	Temperature Coeff. of Breakdown Voltage	—	0.69	—	V/°C	$V_{GE} = 0V, I_C = 1mA$
$V_{CE(on)}$	Collector-to-Emitter Voltage	—	1.59	1.8	V	$I_C = 17A, V_{GE} = 15V$
		—	1.99	—		$I_C = 31A$ See Fig. 2, 5
		—	1.7	—		$I_C = 17A, T_J = 150^\circ\text{C}$
$V_{GE(th)}$	Gate Threshold Voltage	3.0	—	6.0	V	$V_{CE} = V_{GE}, I_C = 250\mu A$
$\Delta V_{GE(th)}/\Delta T_J$	Threshold Voltage temp. coefficient	—	-11	—	mV/°C	$V_{CE} = V_{GE}, I_C = 250\mu A$
$g_{fe}$	Forward Transconductance ④	6.1	10	—	S	$V_{CE} = 100V, I_C = 17A$
$I_{CES}$	Zero Gate Voltage Collector Current	—	—	250	$\mu A$	$V_{GE} = 0V, V_{CE} = 600V$
		—	—	2500		$V_{GE} = 0V, V_{CE} = 600V, T_J = 150^\circ\text{C}$
$V_{FM}$	Diode Forward Voltage Drop	—	2.0	2.4	V	$I_F = 8.0A$ See Fig. 13
		—	1.3	1.8		$I_F = 8.0A, T_J = 150^\circ\text{C}$
$I_{GES}$	Gate-to-Emitter Leakage Current	—	—	$\pm 100$	nA	$V_{GE} = \pm 20V$

## Switching Characteristics @ $T_J = 25^\circ\text{C}$ (unless otherwise specified)

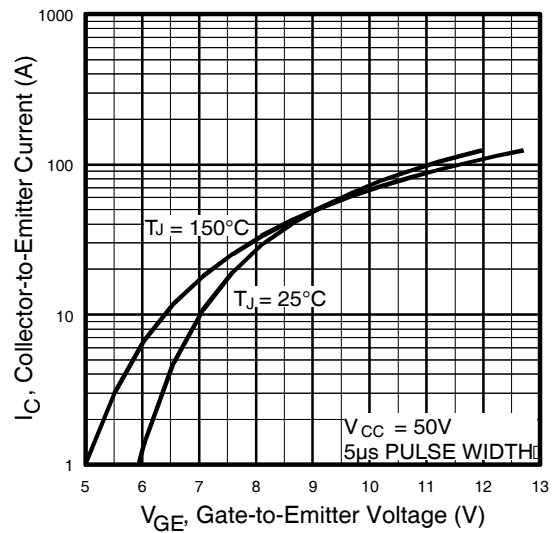
	Parameter	Min.	Typ.	Max.	Units	Conditions
$Q_g$	Total Gate Charge (turn-on)	—	57	62	nC	$I_C = 17A$
$Q_{ge}$	Gate-to-Emitter Charge (turn-on)	—	10	12		$V_{CC} = 400V$ See Fig. 8
$Q_{gc}$	Gate-to-Collector Charge (turn-on)	—	21	24		$V_{GE} = 15V$
$t_{d(on)}$	Turn-On delay time	—	22	—	ns	$T_J = 25^\circ\text{C}$
$t_r$	Rise time	—	24	—		$I_C = 17A, V_{CC} = 480V$
$t_{d(off)}$	Turn-Off delay time	—	250	320		$V_{GE} = 15V, R_G = 23\Omega$
$t_f$	Fall time	—	160	210		Energy losses include "tail" and diode reverse recovery.
$E_{on}$	Turn-On Switching Loss	—	370	—		See Fig. 9, 10, 11, 18
$E_{off}$	Turn-Off Switching Loss	—	1420	—	$\mu J$	
$E_{ts}$	Total Switching Loss	—	1800	2290		
$t_{d(on)}$	Turn-On delay time	—	21	—	ns	$T_J = 150^\circ\text{C}$ See Fig. 9,10,11,18
$t_r$	Rise time	—	25	—		$I_C = 17A, V_{CC} = 480V$
$t_{d(off)}$	Turn-Off delay time	—	400	—		$V_{GE} = 15V, R_G = 23\Omega$
$t_f$	Fall time	—	340	—		Energy losses include "tail" and diode reverse recovery.
$E_{ts}$	Total Switching Loss	—	3280	—		$\mu J$
$L_E$	Internal Emitter Inductance	—	7.5	—	nH	Measured 5mm from package
$C_{ies}$	Input Capacitance	—	1170	—	pF	$V_{GE} = 0V$
$C_{oes}$	Output Capacitance	—	100	—		$V_{CC} = 30V$ See Fig. 7
$C_{res}$	Reverse Transfer Capacitance	—	11	—		$f = 1.0MHz$
$t_{rr}$	Diode Reverse Recovery Time	—	46	61	ns	$T_J = 25^\circ\text{C}$ See Fig.
		—	85	93		$T_J = 125^\circ\text{C}$ 14
$I_{rr}$	Diode Peak Reverse Recovery Current	—	4.8	6.5	A	$T_J = 25^\circ\text{C}$ See Fig.
		—	8.5	10		$T_J = 125^\circ\text{C}$ 15
$Q_{rr}$	Diode Reverse Recovery Charge	—	110	190	nC	$T_J = 25^\circ\text{C}$ See Fig.
		—	410	550		$T_J = 125^\circ\text{C}$ 16
$di_{(rec)M}/dt$	Diode Peak Rate of Fall of Recovery During $t_b$	—	260	—	A/ $\mu s$	$T_J = 25^\circ\text{C}$ See Fig.
		—	270	—		$T_J = 125^\circ\text{C}$ 17



**Fig. 1 - Typical Load Current vs. Frequency**  
 (For square wave,  $I = I_{\text{RMS}}$  of fundamental; for triangular wave,  $I = I_{\text{PK}}$ )

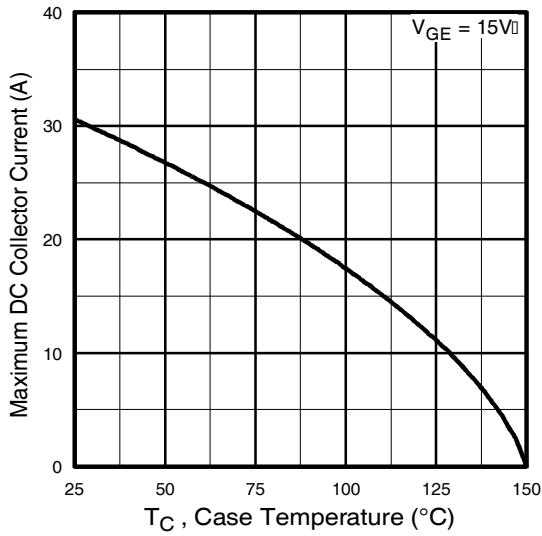


**Fig. 2 - Typical Output Characteristics**

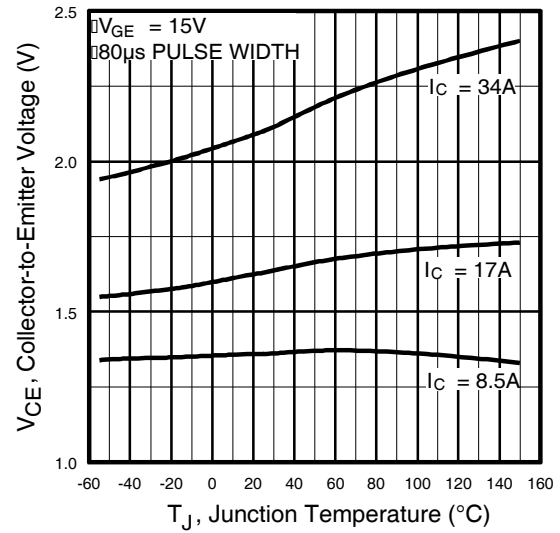


**Fig. 3 - Typical Transfer Characteristics**

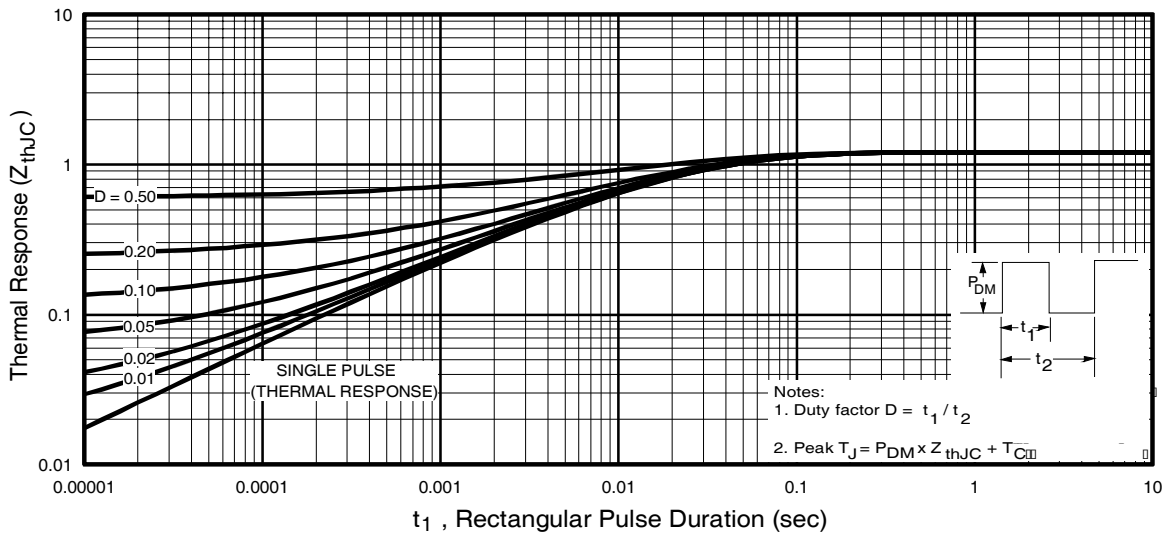
# IRG4BC30FD1PbF



**Fig. 4 - Maximum Collector Current vs. Case Temperature**

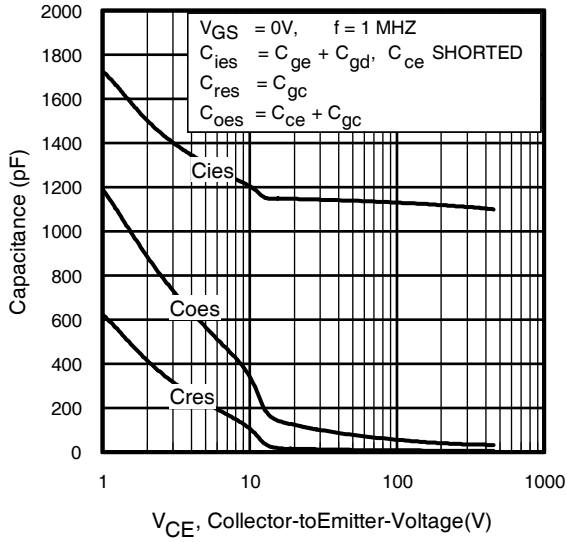


**Fig. 5 - Typical Collector-to-Emitter Voltage vs. Junction Temperature**

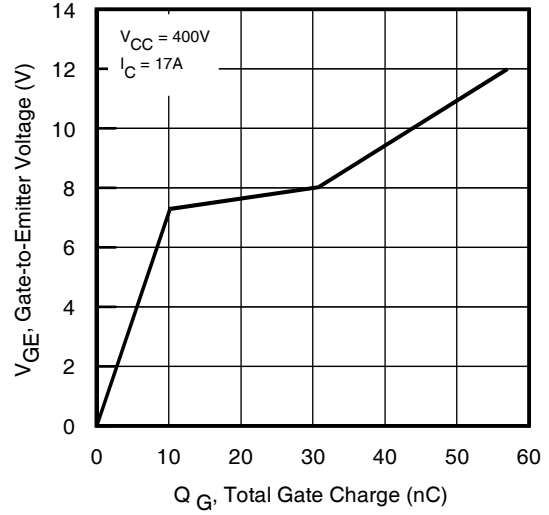


**Fig. 6 - Maximum Effective Transient Thermal Impedance, Junction-to-Case**

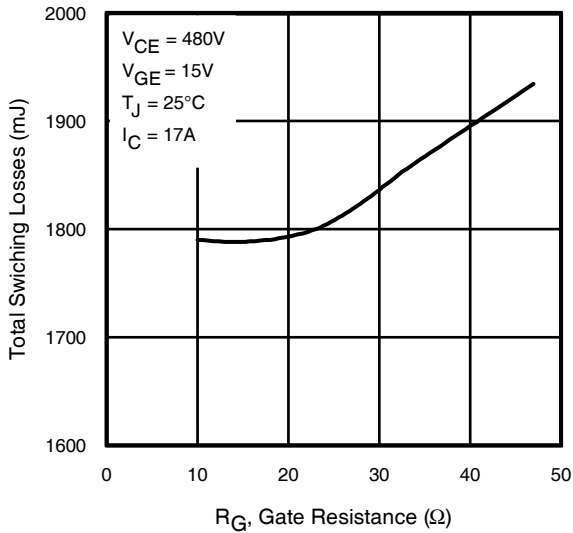
# IRG4BC30FD1PbF



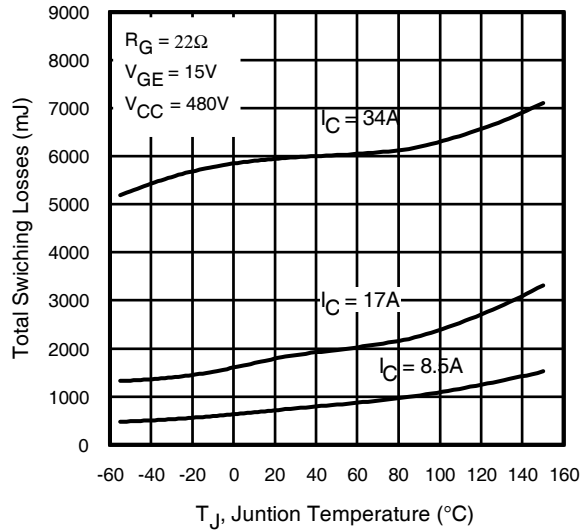
**Fig. 7 - Typical Capacitance vs. Collector-to-Emitter Voltage**



**Fig. 8 - Typical Gate Charge vs. Gate-to-Emitter Voltage**

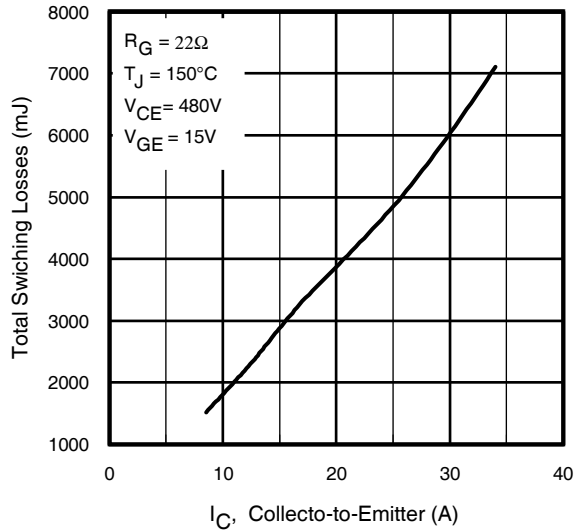


**Fig. 9 - Typical Switching Losses vs. Gate Resistance**

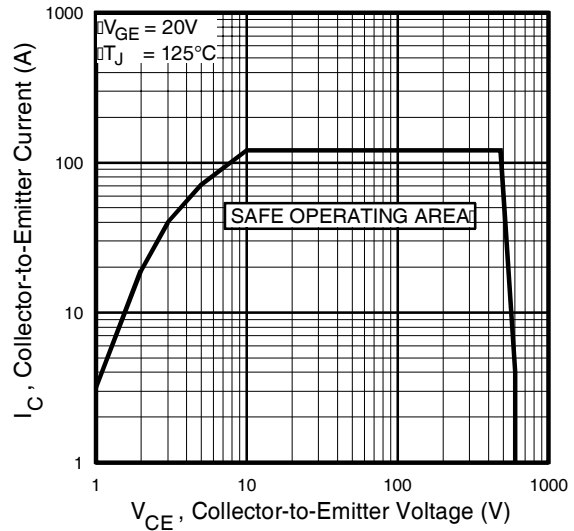


**Fig. 10 - Typical Switching Losses vs. Junction Temperature**

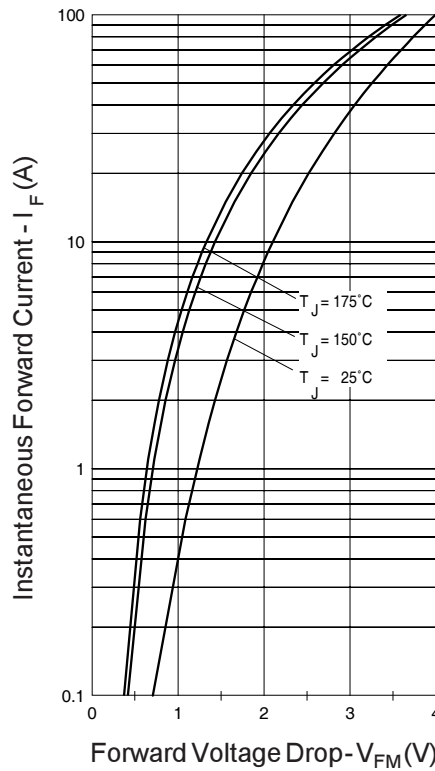
# IRG4BC30FD1PbF



**Fig. 11** - Typical Switching Losses vs. Collector-to-Emitter Current

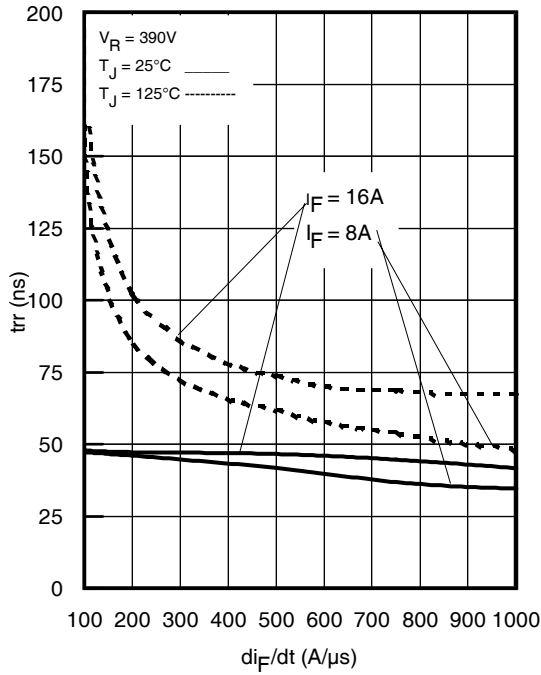


**Fig. 12** - Turn-Off SOA

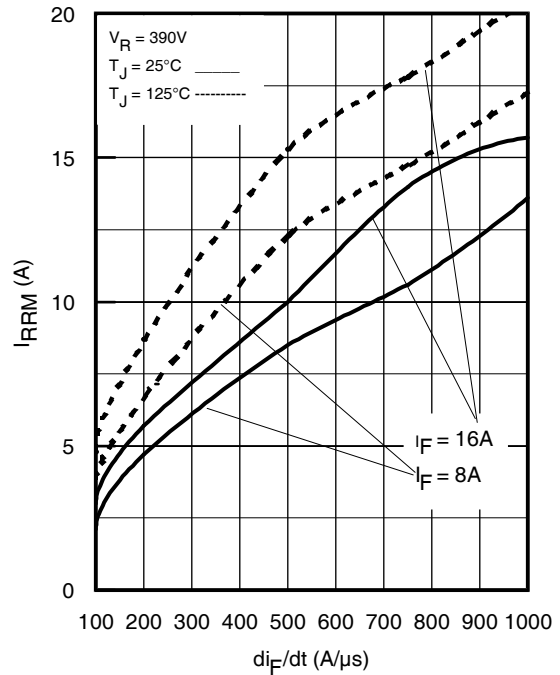


**Fig. 13** - Maximum Forward Voltage Drop vs. Instantaneous Forward Current

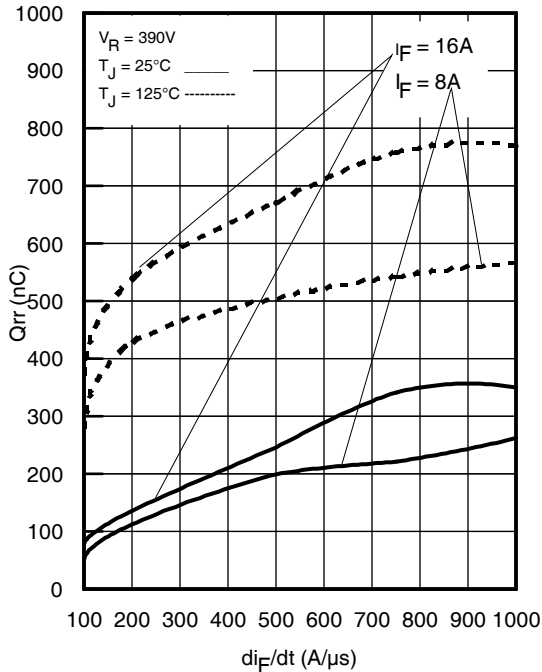
# IRG4BC30FD1PbF



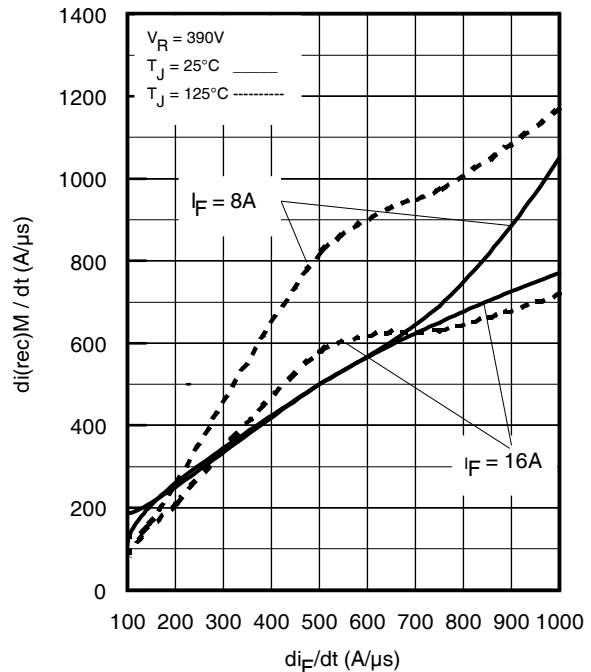
**Fig. 14 - Typical Reverse Recovery vs.  $di_F/dt$**



**Fig. 15 - Typical Recovery Current vs.  $di_F/dt$**

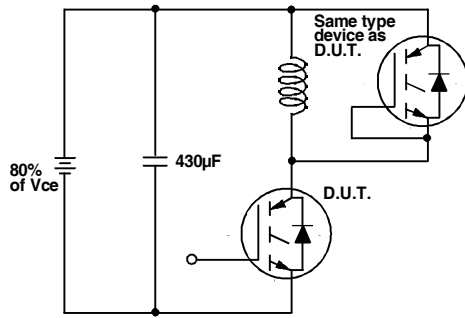


**Fig. 16 - Typical Stored Charge vs.  $di_F/dt$**

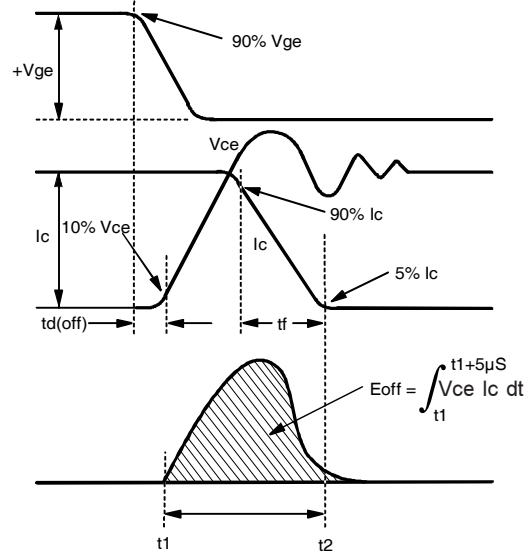


**Fig. 17 - Typical  $di_{(rec)M}/dt$  vs.  $di_F/dt$**

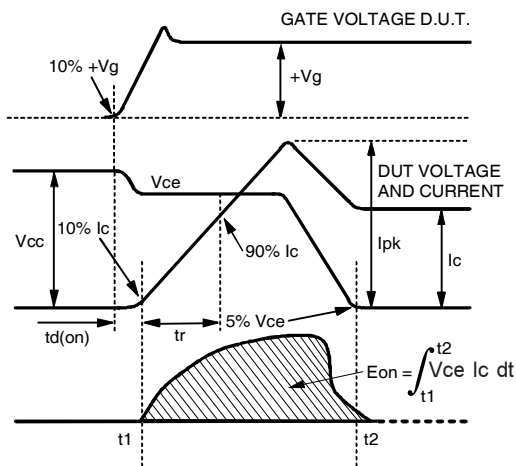
# IRG4BC30FD1PbF



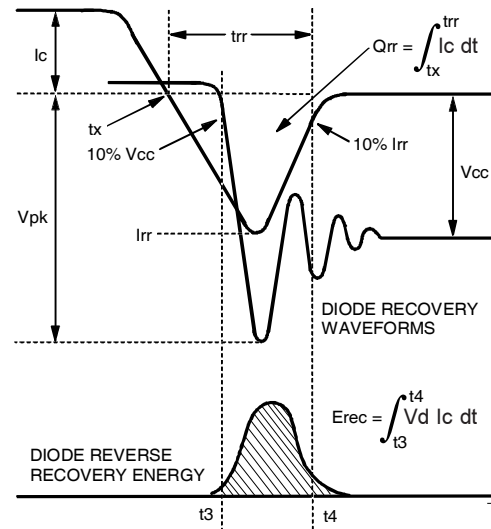
**Fig. 18a** - Test Circuit for Measurement of  $I_{LM}$ ,  $E_{on}$ ,  $E_{off}(\text{diode})$ ,  $t_{rr}$ ,  $Q_{rr}$ ,  $I_{rr}$ ,  $t_{d(on)}$ ,  $t_r$ ,  $t_{d(off)}$ ,  $t_f$



**Fig. 18b** - Test Waveforms for Circuit of Fig. 18a, Defining  $E_{off}$ ,  $t_{d(off)}$ ,  $t_f$

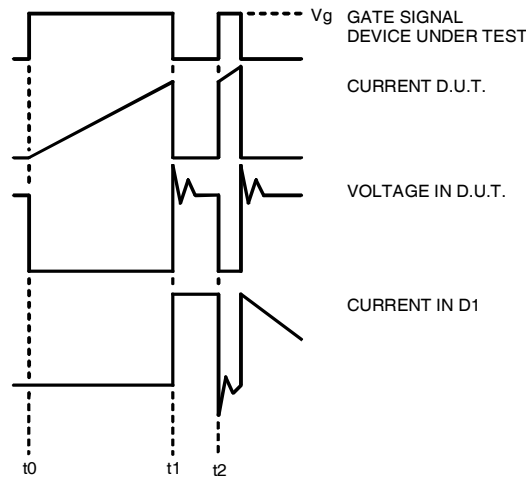


**Fig. 18c** - Test Waveforms for Circuit of Fig. 18a, Defining  $E_{on}$ ,  $t_{d(on)}$ ,  $t_r$

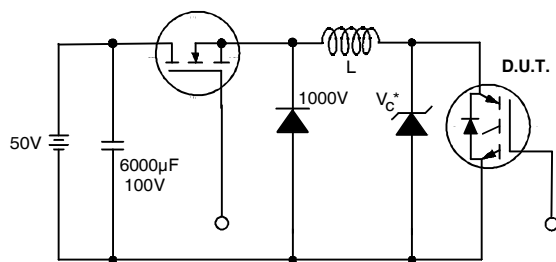


**Fig. 18d** - Test Waveforms for Circuit of Fig. 18a, Defining  $E_{rec}$ ,  $t_{rr}$ ,  $Q_{rr}$ ,  $I_{rr}$

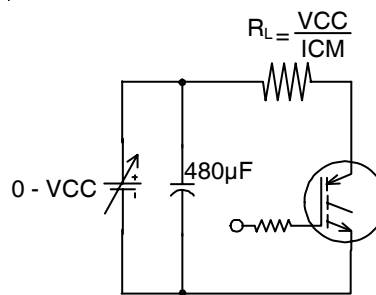




**Fig.18e** - Macro Waveforms for Figure 18a's Test Circuit



**Fig. 19** - Clamped Inductive Load Test Circuit

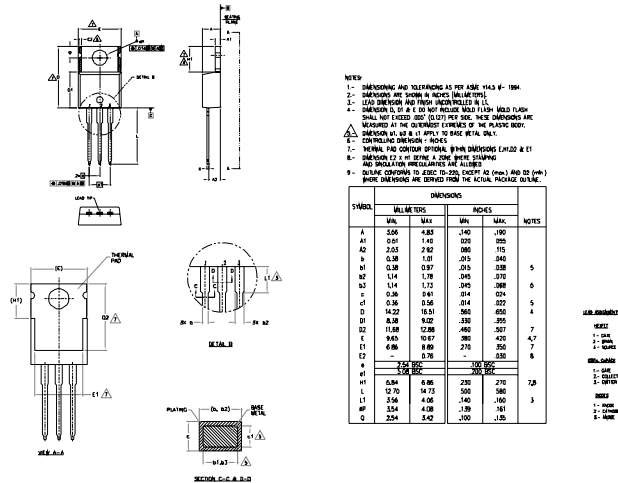


**Pulsed Collector Current Test Circuit**

**Fig. 20** - Pulsed Collector Current Test Circuit

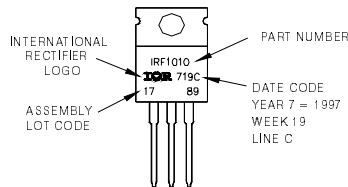
# IRG4BC30FD1PbF

TO-220AB Package Outline (Dimensions are shown in millimeters (inches))



## TO-220AB Part Marking Information

EXAMPLE: THIS IS AN IRF1010  
LOT CODE 1789  
ASSEMBLED ON WW 19, 1997  
IN THE ASSEMBLY LINE 'C'  
**Note:** "P" in assembly line position indicates "Lead-Free"



**Note:** For the most current drawing please refer to IR website at <http://www.irf.com/package/>

### Notes:

- ① Repetitive rating:  $V_{GE}=20V$ ; pulse width limited by maximum junction temperature (figure 20).
- ②  $V_{CC}=80\%(V_{CES})$ ,  $V_{GE}=20V$ ,  $L=10\mu H$ ,  $R_G = 23\Omega$  (figure 19).
- ③ Pulse width  $\leq 80\mu s$ ; duty factor  $\leq 0.1\%$ .
- ④ Pulse width  $5.0\mu s$ , single shot.
- ⑤ Energy losses include "tail" and diode reverse recovery, using Diode FD100H06A5.

Data and specifications subject to change without notice.  
This product has been designed and qualified for the Industrial market.  
Qualification Standards can be found on IR's Web site.

# Mouser Electronics

Authorized Distributor

Click to View Pricing, Inventory, Delivery & Lifecycle Information:

[International Rectifier:](#)

[IRG4BC30FD1PBF](#)