

## FEATURES

- Drives both high-side and low-side MOSFETs in a synchronous buck configuration
- Large drivers designed to drive 6nF server class FETs
  - Low-side driver – 4A source / 6A sink
  - High-side driver – 3A source / 4A sink
  - Transition times & propagation delays < 20ns
- Independent variable gate drive voltage for both high- and low-side drivers from 4.5V to 13.2V
  - Improves efficiency
  - Compatible with IR controller VGD feature
- Integrated bootstrap diode
  - Reduces external component count
- Capable of high switching frequencies from 200kHz up to 1MHz
- Configurable PWM modes of operation
  - IR Active Tri-Level (ATL), disables both MOSFETs in 30ns with no hold-off time
  - Generic Tri-State PWM with hold-off
- Adaptive non-overlap protection minimizes diode conduction time
- Input supply under voltage protection
- Thermally enhanced 10-pin DFN package
- Lead free RoHS compliant package, MSL level 1

## APPLICATIONS

- Multiphase synchronous buck converter for Server and desktop computers using Intel® and AMD® VR solutions
- High efficiency and compact VRM
- High current DC/DC converters

## DESCRIPTION

The IR3537/CHL8510 is a high efficiency gate driver which can switch both high-side and low-side N-channel external MOSFETs in a synchronous buck converter. It is intended for use with International Rectifier’s Digital PWM controllers to provide a total voltage regulator (VR) solution for today’s advanced computing applications.

The IR3537/CHL8510 low-side driver is capable of rapidly switching large MOSFETs with low  $R_{DS(on)}$  and large input capacitance used in high efficiency designs.

The IR3537/CHL8510 features individual control of both the high-and low-side gate drive voltages from 4.5V to 13.2V. This enables the optimization of switching and conduction losses in the external MOSFETs. When used with IR’s proprietary Variable Gate Drive (VGD) technology, a significant improvement in efficiency is observed across the entire load range.

The IR3537/CHL8510 can be configured to drive both the high- and low-side switches from the unique IR fast Active Tri-Level (ATL) PWM signal or a generic tri-state PWM mode. The IR ATL mode allows the controller to disable the high- and low-side FETs in less than 30ns without the need for a dedicated disable pin. This improves VR transient performance, especially during load release.

The integrated bootstrap diode reduces external component count. The IR3537/CHL8510 also features an adaptive non-overlap control for shoot-through protection. This prevents cross conduction of both high-side and low-side MOSFETs and minimizes body diode conduction time to provide the best in class efficiency.

## BASIC APPLICATION

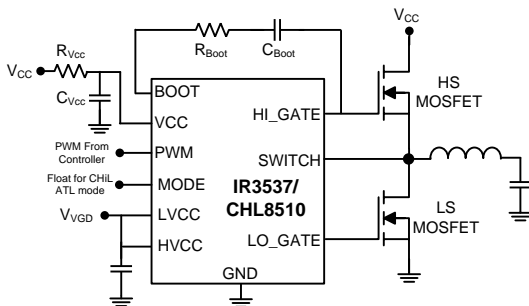

Figure 1: Basic Applications Circuit

## PIN DIAGRAM

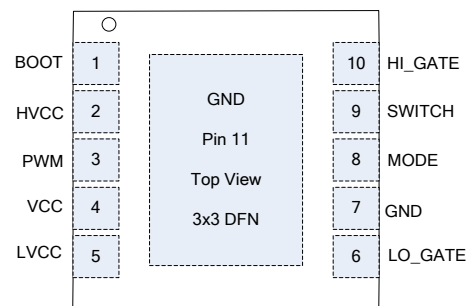
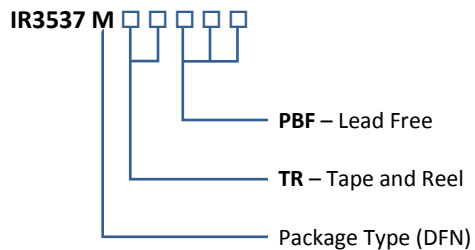
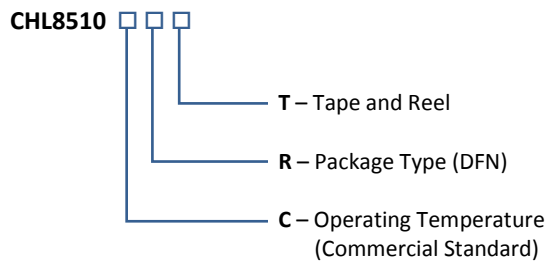

Figure 2: IR3537/CHL8510 Package Top View

## ORDERING INFORMATION



Package	Tape & Reel Qty	Part Number
<b>DFN</b>	3000	<b>IR3537MTRPBF</b>
<b>DFN</b>	750	<b>IR3537MTR1PBF</b>



Package	Tape & Reel Qty	Part Number
<b>DFN</b>	3000	<b>CHL8510CRT</b>

# Mouser Electronics

Authorized Distributor

Click to View Pricing, Inventory, Delivery & Lifecycle Information:

[International Rectifier:](#)

[IR3537MTRPBF](#)