

PWM Doubler with Output Monitoring Feature

ISL6617A

The ISL6617A utilizes Intersil's proprietary Phase Doubler scheme to modulate two-phase power trains with single PWM input. It doubles the number of phases that 3.3V multiphase controllers can support.

The ISL6617A is designed to minimize the number of analog signals that interface between the controller and drivers in high phase count scalable applications. The common COMP signal, which is usually seen in conventional cascaded configurations, is not required; this improves noise immunity and simplifies the layout. Furthermore, the ISL6617A provides low part count and low cost advantage over the conventional cascaded technique.

By cascading the ISL6617A with another ISL6617 or ISL6611A, it can quadruple the number of phases that 3.3V multiphase controllers can support.

The ISL6617A also features tri-state input and outputs that recognize a high-impedance state, working together with Intersil multiphase PWM controllers and driver stages to prevent negative transients on the controlled output voltage when operation is suspended. This feature eliminates the need for the Schottky diode that may be utilized in a power system to protect the load from excessive negative output voltage damage.

Applications

- High current low voltage DC/DC converters
- High frequency and high efficiency VRM and VRD
- High phase count and phase shedding applications
- 3.3V PWM input integrated power stage or DrMOS

Features

- Proprietary phase doubler scheme
- Enhanced light to full load efficiency
- Double or quadruple phase count
- Patented current balancing with DCR current sensing and adjustable gain
- Current monitoring output (I_{OUT}) to simplify system interface and layout
- Triple-level enable input for mode selection
- Dual PWM output drives for two synchronous rectified bridges with single PWM input
- Channel synchronization and two interleaving options
- Support 3.3V PWM input
- Support 5V PWM output
- Tri-state PWM input and outputs for output stage shutdown
- Overvoltage protection
- Dual flat no-lead (DFN) package
 - Near chip-scale package footprint; improves PCB utilization, thinner profile
 - Pb-free (RoHS compliant)

Related Literature

- [TB363](#), "Guidelines for Handling and Processing Moisture Sensitive Surface Mount Devices (SMDs)"

Phase Doubler Selection Guide

PART NUMBER	PWM INPUT	PWM OUTPUT	INTEGRATED DRIVER	CASCADED DEVICES	COMPATIBLE CONTROLLERS
ISL6617	5.0V	5.0V	N/A	5.0V PWM DrMOS; ISL6617, ISL6611A	ISL6336G, ISL6372/3/4/5/6, ISL6364/67/67H; ISL6388/98 with 5V PWM Option
ISL6617A	3.3V	5.0V	N/A	5.0V PWM DrMOS; ISL6617, ISL6611A	3.3V PWM Digital Controllers with Phase Doubler Compatibility; ISL6388/98 with 3.3V PWM Option
ISL6611A	5V	N/A	5.0V	Discrete MOSFET; Dual FETS	ISL6336G, ISL6372/3/4/5/6, ISL6364/67/67H; ISL6388/98 with 5V PWM Option

ISL6617A

Internal Block Diagram

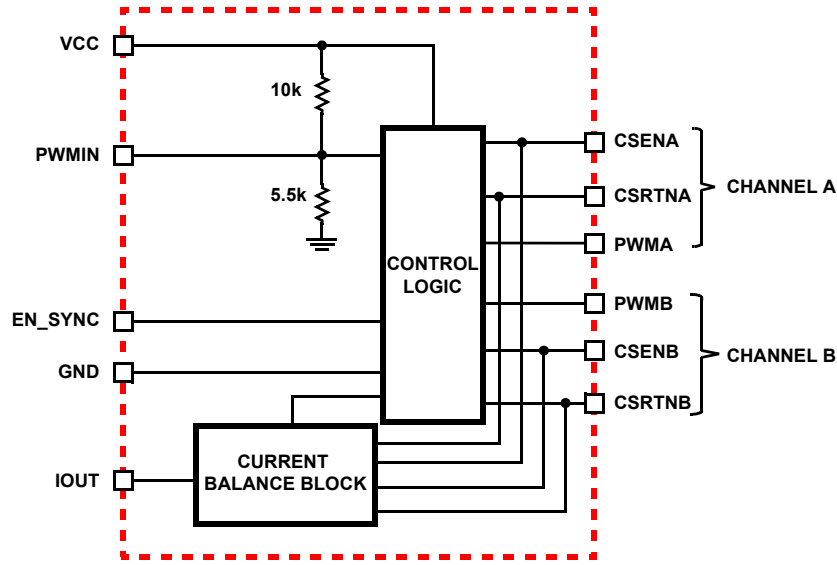

Ordering Information

PART NUMBER (Notes 1, 2, 3)	PART MARKING	TEMP. RANGE (°C)	PACKAGE (RoHS Compliant)	PKG. DWG. #
ISL6617AFRZ	17AF	-40 to +125	10 Ld 3x3 DFN	L10.3x3

NOTES:

1. Add "-T*" suffix for tape and reel. Please refer to [TB347](#) for details on reel specifications.
2. These Intersil Pb-free plastic packaged products employ special Pb-free material sets, molding compounds/die attach materials, and 100% matte tin plate plus anneal (e3 termination finish, which is RoHS compliant and compatible with both SnPb and Pb-free soldering operations). Intersil Pb-free products are MSL classified at Pb-free peak reflow temperatures that meet or exceed the Pb-free requirements of IPC/JEDEC J STD-020.
3. For information on MSL please see techbrief [TB363](#).

ISL6617A

Pin Configuration

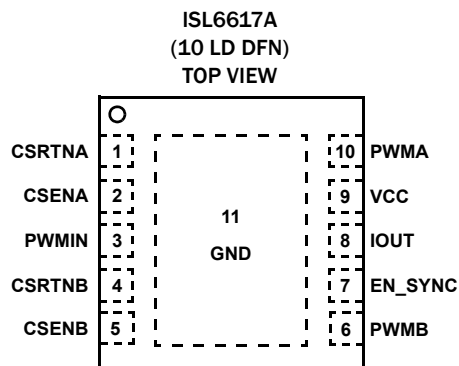

Functional Pin Descriptions

PIN #	PIN SYMBOL	FUNCTION
1	CSRTNA	Output of the differential amplifier for Channel A. Connect a resistor on this pin to the negative rail of the sensed voltage to set the current gain.
2	CSENA	Input of the differential amplifier for Channel A. Typically, the positive rail of sensed voltage via DCR sensing network connects to this node.
3	PWMIN	The PWM input signal (3.3V) triggers the J-K flip flop and alternates its input to Channel A and B. Both channels are effectively modulated. The PWM signal can enter three distinct states during operation; see "Operation" on page 8 for further details. Connect this pin to the PWM output of the controller.
4	CSRTNB	Output of the differential amplifier for Channel B. Connect a resistor on this pin to the negative rail of the sensed voltage to set the current gain.
5	CSENB	Input of the differential amplifier for Channel B. Typically, the positive rail of sensed voltage via DCR sensing network connects to this node.
6	PWMB	PWM output of Channel B with 5V PWM tri-state compatibility.
7	EN_SYNC	Driver Enable and Mode Selection Input. See "EN_SYNC Operation" on page 8 for more details.
8	IOOUT	Current monitoring Output. It sources out the average current of both Channel A and B.
9	VCC	Connect this pin to a +5V bias supply. It supplies power to internal analog circuits. Place a high quality low ESR ceramic capacitor from this pin to GND.
10	PWMA	PWM output of Channel A with 5V PWM tri-state compatibility.
11	GND	Bias and reference ground. All signals are referenced to this node. Place a high quality low ESR ceramic capacitor from this pin to VCC. Connect this pad to the power ground plane (GND) via thermally enhanced connection.

ISL6617A

Typical Application (2-Phase Controller for 4-Phase Operation)

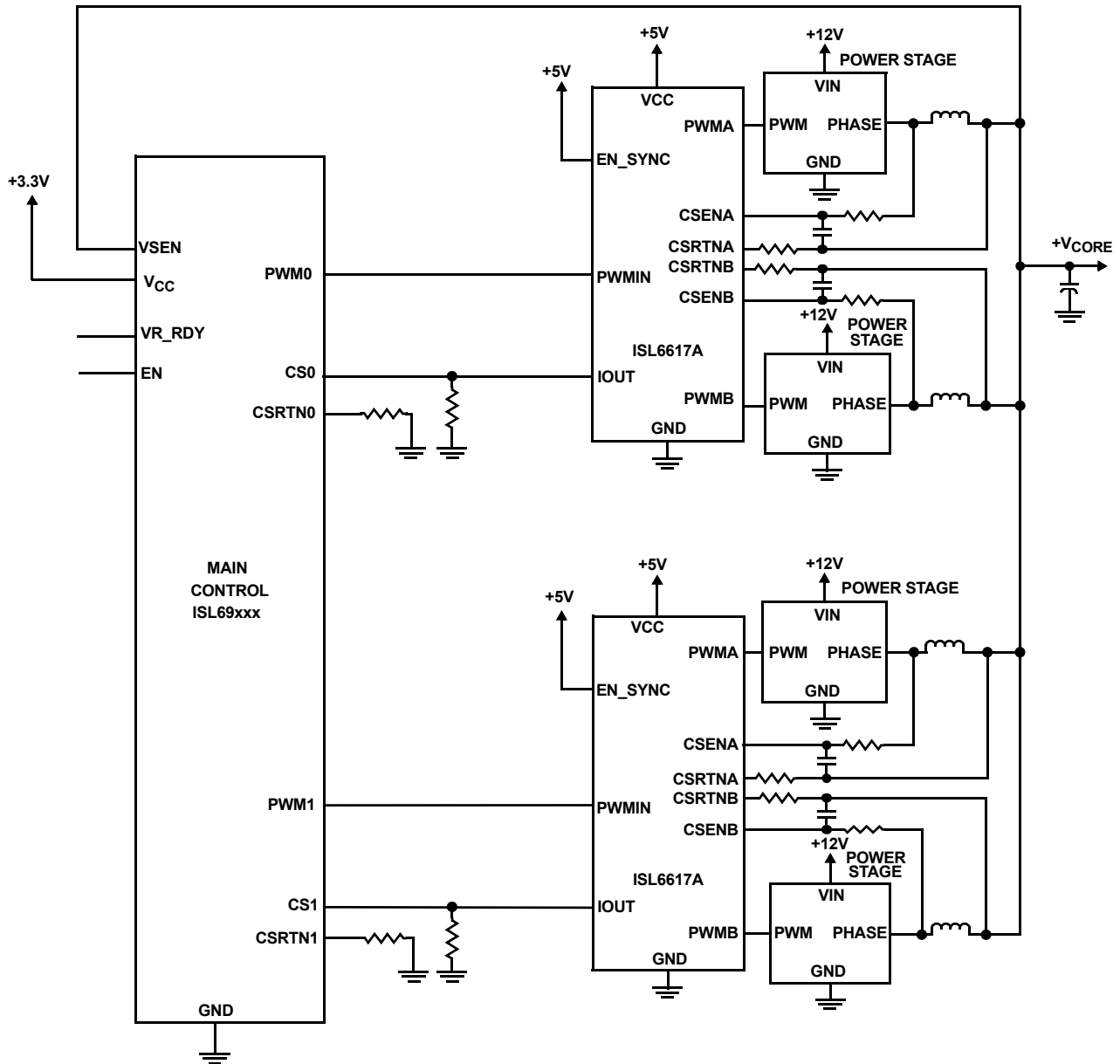

ISL6617A

Typical Application II (2-Phase Controller to 8-Phase Operation)

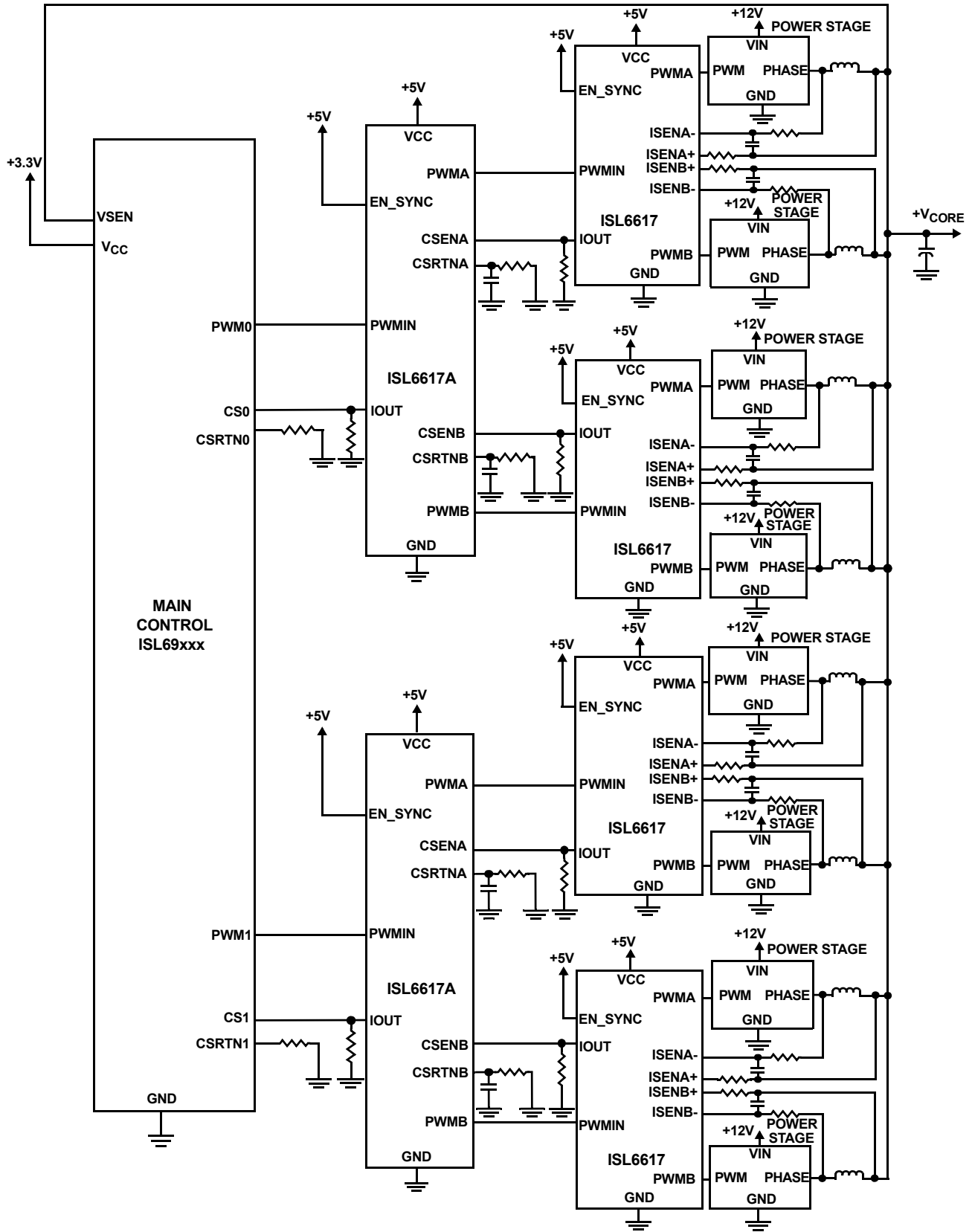

ISL6617A

Absolute Maximum Ratings

Supply Voltage (VCC)	-0.3V to 6.7V
Input Voltage (V _{ENx} , V _{PWMIN} , I _{SENx})	-0.3V to VCC + 0.3V
Ambient Temperature Range	-40 °C to +125 °C
ESD Rating	
Human Body Model (JEDEC Class 2)	2kV
Machine Model (JEDEC Class B)	200V
Charged Device Model (JEDEC Class IV)	2kV
Latch-up (JEDEC Class II)	+85 °C

Thermal Information

Thermal Resistance (Typical)	θ_{JA} (°C/W)	θ_{JC} (°C/W)
10 Ld DFN (Notes 4, 5)	48	7
Maximum Junction Temperature	+150 °C	
Maximum Storage Temperature Range	-65 °C to +150 °C	
Pb-Free Reflow Profile	see TB493	

Recommended Operating Conditions

Ambient Temperature	-40 °C to +125 °C
Maximum Operating Junction Temperature	+125 °C
Supply Voltage, VCC	5V ±10%

CAUTION: Do not operate at or near the maximum ratings listed for extended periods of time. Exposure to such conditions may adversely impact product reliability and result in failures not covered by warranty.

NOTES:

- θ_{JA} is measured in free air with the component mounted on a high effective thermal conductivity test board with “direct attach” features. See Tech Brief [TB379](#).
- θ_{JC} , “case temperature” location is at the center of the package underside exposed pad.

Electrical Specifications These specifications apply for recommended ambient temperature, unless otherwise noted. **Boldface limits apply over the operating temperature range.**

PARAMETER	SYMBOL	TEST CONDITIONS	MIN (Note 6)	TYP	MAX (Note 6)	UNITS
SUPPLY CURRENT						
Bias Supply Current	I _{VCC}	PWM pin floating, V _{VCC} = 5V, EN_SYNC = 5V		5	6.5	mA
		PWM pin floating, V _{VCC} = 5V, EN_SYNC = 0V		5	6.5	mA
		F _{PWM} = 600kHz, V _{VCC} = 5V, EN_SYNC = 5V		6	7.5	mA
		F _{PWM} = 600kHz, V _{VCC} = 5V, EN_SYNC = 4.25V		6	7.5	mA
		F _{PWM} = 300kHz, V _{VCC} = 5V, EN_SYNC = 3.25V		6	7.5	mA
POWER-ON RESET						
POR Rising				3.4	4.2	V
POR Falling			2.3	3.0		V
Hysteresis				350		mV
EN_SYNC INPUT						
ENx Minimum LOW Threshold	V _{ENx}				0.8	V
ENx Maximum HIGH Threshold	V _{ENx}		2.0			V
SYNC AND INTERLEAVING MODE						
Interleaving Mode 1 Window	V _{ENx}		97%			VCC
Interleaving Mode 2 Window	V _{ENx}		78%		85%	VCC
Synchronous Mode Window	V _{ENx}		54%		64%	VCC
Typical Threshold Hysteresis				-5%		VCC
Minimum SYNC Pulse					40	ns
Maximum Synchronization Delay			50			ns
Interleaving Mode Phase Shift		SYNC = 5V, PWM = 300kHz, 10% Width		180		°
Synchronization Mode Phase Shift		SYNC = 0V, PWM = 300kHz, 10% Width		0		°
PWM INPUT (PWMIN)						
Sinking Impedance	R _{PWM_SNK}			5.5		kΩ
Source Impedance	R _{PWM_SRC}			10		kΩ

ISL6617A

Electrical Specifications These specifications apply for recommended ambient temperature, unless otherwise noted. **Boldface limits apply over the operating temperature range. (Continued)**

PARAMETER	SYMBOL	TEST CONDITIONS	MIN (Note 6)	TYP	MAX (Note 6)	UNITS
Tri-State to PWM High Rising Threshold		$V_{VCC} = 5V$		2.50	2.70	V
Tri-State to PWM High Falling Threshold		$V_{VCC} = 5V$	2.00	2.25		V
Tri-State to PWM Low Rising Threshold		$V_{VCC} = 5V$		0.95	1.15	V
Tri-State to PWM Low Falling Threshold		$V_{VCC} = 5V$	0.50	0.75		V
CURRENT SENSE (CSENA, CSENB, IOUT) AND PROTECTION (IOUT)						
Sensed Current Tolerance	I _{OUT}	CSENA = CSENB = 0 μ A	-6	0	6	μ A
		CSENA = CSENB = 20 μ A	14	20	26	μ A
		CSENA = CSENB = 50 μ A	43	50	57	μ A
		CSENA = CSENB = 100 μ A	90	100	110	μ A
Un-Tri State Trip for OVP	I _{OUT}	ENx = LOW TO HIGH, PWM = LOW	40	60	90	μ A
PWM OUTPUT (PWMA AND PWMB)						
Sourcing Impedance	R _{PWM_SRC}	VCC = 5V, PWMIN = HIGH	30	100	200	Ω
Sink Impedance	R _{PWM_SNK}	VCC = 5V, PWMIN = LOW	30	100	150	Ω
PWM Output High Level	V _{PWMA/B}	VCC = 5V, PWMIN = HIGH, 2.5mA Load	4.5			V
PWM Output Low Level	V _{PWMA/B}	VCC = 5V, PWMIN = LOW, 2.5mA Load			0.4	V
PWM Tri-State Level	V _{PWMA/B}	VCC = 5V, EN_PH = LOW, 0.5mA Load	1.65	2.00	2.6	V
SWITCHING TIME (See Figure 1 on page 8)						
PWMA/B Low to High Rise Time	t _{R1}	Unloaded, 10% to 90%		4.5		ns
PWMA/B Tri-State to High Rise Time	t _{R2}	Unloaded, 10% to 90%		4.5		ns
PWMA/B High to Low Fall Time	t _{F1}	Unloaded, 90% to 10%		4.0		ns
PWMA/B High to Tri-state Fall Time	t _{F2}	100% to 60% (3V), Assume Equivalent Loading of RC = 50k Ω *10pF = 500ns		255		ns
PWMA/B Turn-on Propagation Delay	t _{PDH}	Outputs Unloaded		35		ns
PWMA/B Turn-off Propagation Delay	t _{PDL}	Outputs Unloaded, excluding extension		35		ns
PWMA/B Extension	t _{EXT}	ENx = VCC, I _{PWMA} > I _{PWMB}		70		ns
		ENx = VCC, I _{PWMA} < I _{PWMB}		70		ns
		ENx = 80%*VCC, I _{PWMA} > I _{PWMB}		190		ns
		ENx = 80%*VCC, I _{PWMA} < I _{PWMB}		190		ns
Tri-State to High or Low Propagation Delay	t _{PTS}	Outputs Unloaded, excluding extension		10		ns
Tri-State Shutdown Hold-off Time	t _{TSSHD}	Including Propagation Delay		65		ns

NOTE:

6. Parameters with MIN and/or MAX limits are 100% tested at +25°C, unless otherwise specified. Temperature limits established by characterization and are not production tested.

Timing Diagram

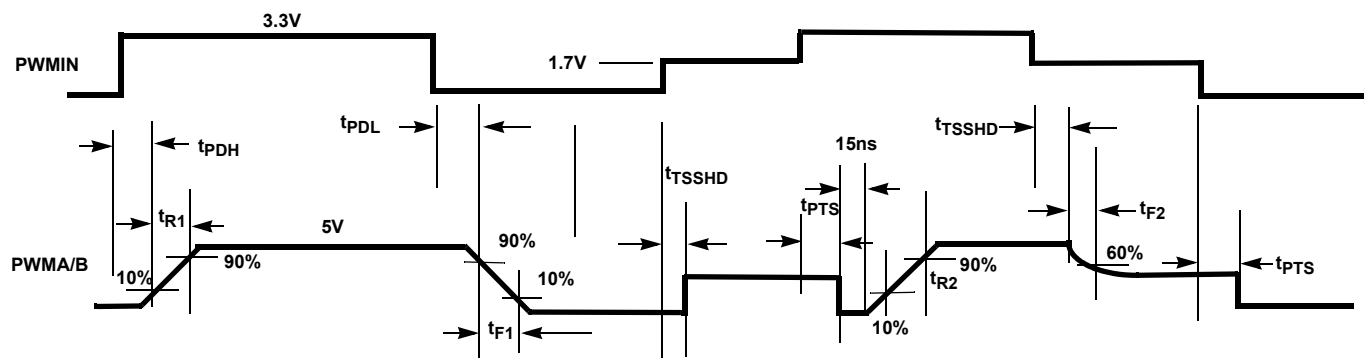

FIGURE 1. TIMING DIAGRAM

Operation

Designed for high phase count and phase shedding applications, the ISL6617A driverless phase doubler is meant to double or quadruple (cascaded with two ISL6617s) the number of phases that 3.3V multiphase controllers can support.

A rising transition on PWMIN initiates the turn-on of the PWMA/B (see Figure 1). After a short propagation delay [t_{PDH}], the PWMA/B begins to rise. Typical rise times [t_{R1}] are provided in the “Electrical Specifications” table on page 7.

A falling transition on PWMIN indicates the turn-off of the PWMA/B. The PWMA/B begins to fall [t_{F1}] after a propagation delay [t_{PDL}], which is modulated by the current balance circuits.

When the PWMIN stays in the tri-state window for longer than [t_{TSSHD}], both PWMA/B will pull to 40% of V_{CC} so that the cascaded 5V PWM input MOSFET driver or integrated power stage can recognize tri-state.

EN_SYNC Operation

The EN_SYNC pin features multiple functions. It is the enable input of the device and the input to select various operational modes.

ENABLE OPERATION

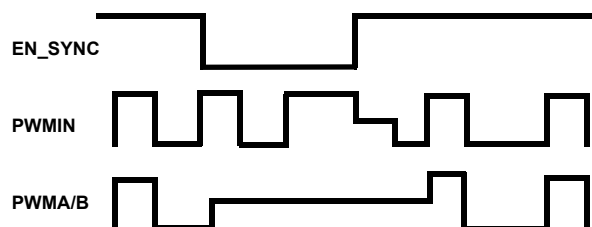

FIGURE 2. TYPICAL ENABLE OPERATION TIMING DIAGRAM

As shown in Figure 2, the ISL6617A disables the doubler operation when the EN_SYNC pin is pulled to ground. When the EN_SYNC returns high, the phase doubler will pull the PWM line into the tri-state window, and then will be enabled only at the leading edge of the PWM input. Prior to the first PWMIN rising edge, both the PWMA and PWMB output will remain in tri-state unless an overvoltage fault is detected. This fault is defined as when a phase is detected to have more than 60% of the

maximum I_{OUT} current. This provides additional protection to the load if the upper MOSFET experiences a short while the doubler is enabled.

The EN_SYNC pin should remain high if driving the PWM line high is prohibited for the associated controller. For proper system interface, please refer to the respective device datasheet.

SYNCHRONOUS OPERATION

The ISL6617A can be set in interleaving mode or synchronous mode by pulling the EN_SYNC pin to the respective level, as shown in Table 1. A synchronous pulse can be sent to the phase doubler during the load application to improve the voltage droop and current balance while still maintaining interleaving operation at DC load conditions. However, excessive ringback can occur; hence, the synchronous mode operation should be carefully investigated. Figure 3 shows how to generate a synchronous pulse when a transient load is applied. The comparator should be a fast comparator with a minimum delay.

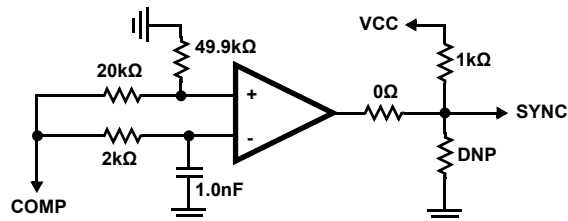

FIGURE 3. TYPICAL SYNC PULSE GENERATOR

VARIOUS OPERATIONAL MODES

The ISL6617A has three distinct operating modes depending upon the voltage level of the EN_SYNC pin. To ensure that the ISL6617A is in operation, the pin must be above 2V. When the EN_SYNC pin is set to above 97% of V_{CC} , the ISL6617A will operate in interleaving mode with a maximum extension of 70ns. When V_{CC} is between 78% and 85% of V_{CC} , the ISL6617A operates in interleaving mode with a fixed extension of 120ns and a variable extension of up to 70ns. This results in a minimum extension of 120ns and a max of 190ns. To enter this 2nd interleaving mode, the pin must remain in the 78% to 85% range for at least 4 cycles. Between 54% and 64% of V_{CC} , the device operates in synchronous mode. Figures 4 and 5 show simplified synchronous and interleaving modes' operational waveforms, respectively.

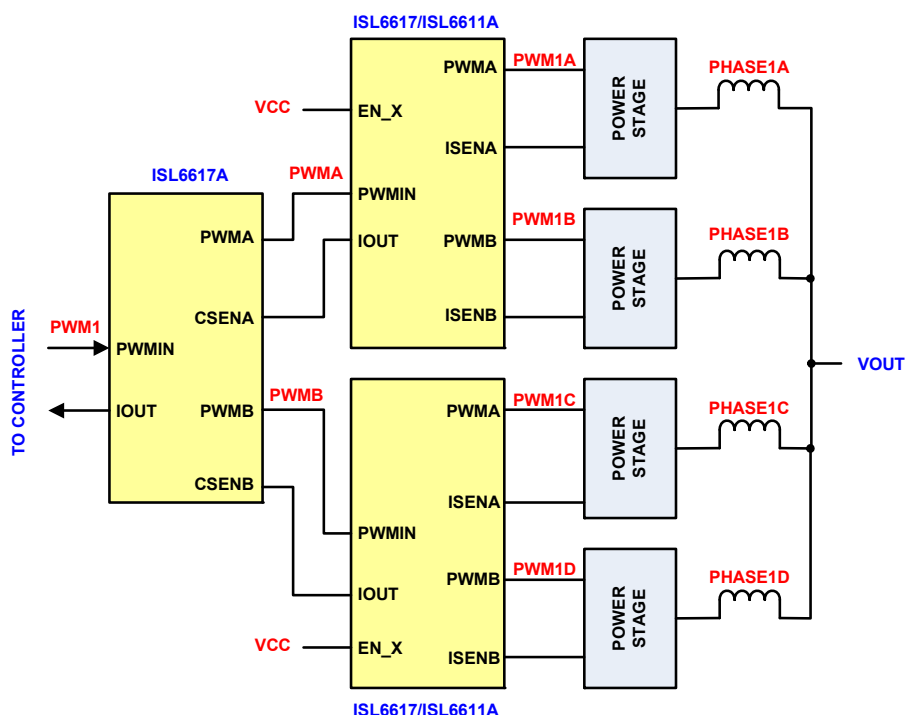

FIGURE 8. CASCADED PHASE DOUBLER SIMPLIFIED DIAGRAM

The ISL6617A can further be cascaded with ISL6617 or ISL6611A (phase doubler with integrated 5V drivers), as shown in [Figure 8](#). This can quadruple the number of phases each PWM line can support. [Figure 9](#) shows the operational waveforms of the cascaded doublers. The PWMIN pin of ISL6617 or ISL6611A will be pulled to VCC when it is disabled (EN_x = Low). To avoid driving the PWM outputs of the 1st stage ISL6617A by the 2nd stage's PWMIN, the 2nd stage doubler's enable input should remain high, i.e., tied to VCC, as shown in [Figure 8](#). Note that ISL6617A cannot cascade with itself and its PWMIN will not be pulled to VCC when EN_x is disabled (Low).

To operate each phase at the switching frequency of f_{SW} , the operational frequency of the controller needs to be scaled accordingly for different modes, as shown in [Table 2](#).

TABLE 2. CONTROLLER FREQUENCY AND MAXIMUM DUTY CYCLE

OPERATIONAL MODES	$F_{CONTROLLER}$	ISL6617A MAXIMUM DUTY CYCLE PER PHASE
Interleaving	$2 \times f_{SW}$	50%
Synchronous	f_{SW}	100%
Cascaded Interleaving	$4 \times f_{SW}$	25%

When the doubler operates in interleaving mode, the PWM controller frequency should be set at two times the desired phase frequency (f_{SW}). Since the input PWM pulse is divided into half to feed into each phase of the doubler, the operational duty cycle of each phase should be less than 50%. In synchronous mode, the PWM controller should be operated at the same frequency as the desired phase frequency. In this mode, the allowable duty cycle is up to 100%. For cascaded interleaving, the controller switching frequency needs to be set at four times the phase frequency. During cascaded operation, the maximum

allowable duty cycle will be less than 25%. All of the maximum allowable duty cycle numbers referenced assume that the PWM controller can send out a 100% duty cycle pulse. In many cases, this is not achievable because the controller needs time to reset its internal sawtooth ramp or internal max duty limit. However, the fixed 120ns extension of interleaving mode 2 helps recover the typical 1% duty cycle loss associated with the ramp reset time.

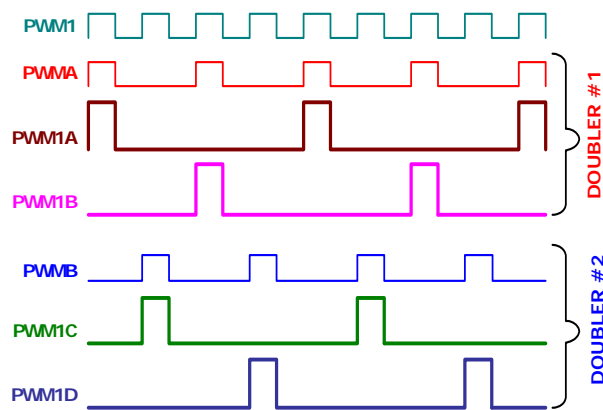

FIGURE 9. CASCADED DOUBLER OPERATIONAL WAVEFORMS

To properly compensate the system that uses phase doublers, the effective system sawtooth to calculate the modulator gain should factor in the duty cycle limitation (D_{MAX}) as [Equation 1](#). For instance, when using ISL6617A and ISL6617 in cascaded interleaving mode, the effective sawtooth amplitude should be scaled as $3V/22.5\% = 13.33V$.

$$V_{RAMP_EFFECTIVE} = \frac{V_{RAMP}}{D_{MAX}} \quad (\text{EQ. 1})$$

Current Sensing

The ISL6617A senses current continuously for fast response. The ISL6617A supports inductor DCR sensing, or resistive sensing techniques. The associated channel current sense amplifier uses the ISEN inputs to reproduce a signal proportional to the inductor current, I_L . The sensed current, I_{SEN} , is proportional to the inductor current. The sensed current is used for current balance and load-line regulation.

The internal circuitry (shown in Figures 10 and 11) represents one channel. This circuitry is repeated for each channel in the doubler. The input bias current of the current sensing amplifier is typically 60nA; less than 5kΩ input impedance is preferred to minimize the offset error. In addition, the common mode input voltage to the amplifier should be less than VCC-3V.

INDUCTOR DCR SENSING

An inductor's winding is characteristic of a distributed resistance, as measured by the DCR (Direct Current Resistance) parameter. Consider the inductor DCR as a separate lumped quantity, as shown in Figure 10.

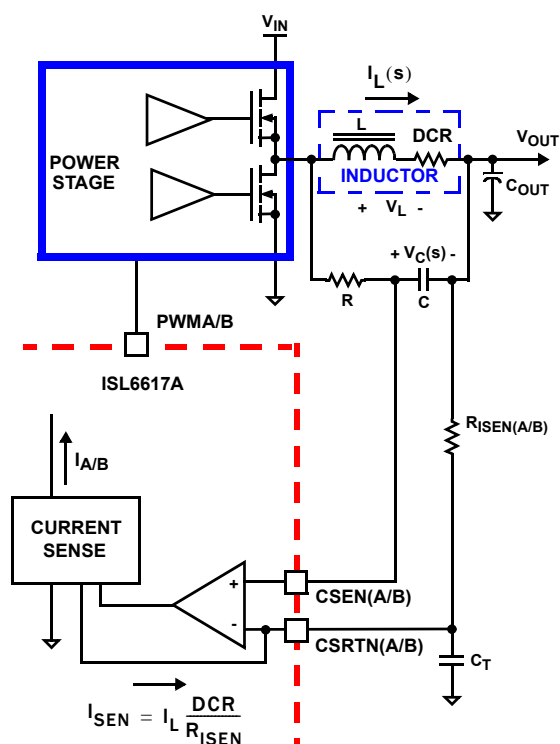

FIGURE 10. DCR SENSING CONFIGURATION

The channel current I_L , flowing through the inductor, will also pass through the DCR. Equation 2 shows the s-domain equivalent voltage across the inductor V_L .

$$V_L(s) = I_L \cdot (s \cdot L + DCR) \quad (\text{EQ. 2})$$

A simple R-C network across the inductor extracts the DCR voltage, as shown in Figure 10.

The voltage on the capacitor V_C , can be shown to be proportional to the channel current I_L . See Equation 3.

$$V_C(s) = \frac{\left(s \cdot \frac{L}{DCR} + 1\right) \cdot (DCR \cdot I_L)}{(s \cdot RC + 1)} \quad (\text{EQ. 3})$$

If the R-C network components are selected such that the RC time constant matches the inductor time constant ($RC = L/DCR$), the voltage across the capacitor V_C is equal to the voltage drop across the DCR, i.e., proportional to the channel current.

With the internal low-offset current amplifier, the capacitor voltage V_C is replicated across the sense resistor R_{ISEN} . Therefore, the current out of ISEN+ pin, I_{SEN} , is proportional to the inductor current.

Because of the internal filter at ISEN- pin, one capacitor, C_T , is needed to match the time delay between the ISEN- and ISEN+ signals. Select the proper C_T to keep the time constant of R_{ISEN} and C_T ($R_{ISEN} \times C_T$) close to 27ns.

Equation 4 shows that the ratio of the channel current to the sensed current, I_{SEN} , is driven by the value of the sense resistor and the DCR of the inductor.

$$I_{SEN} = I_L \cdot \frac{DCR}{R_{ISEN}} \quad (\text{EQ. 4})$$

RESISTIVE SENSING

For more accurate current sensing, a dedicated resistor R_{SENSE} in series with each output inductor can serve as the current sense element (see Figure 11). This technique reduces overall converter efficiency due to the additional power loss on the current sense element R_{SENSE} .

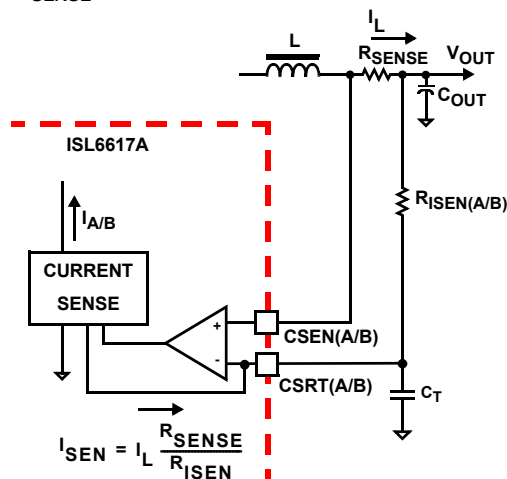

FIGURE 11. SENSE RESISTOR IN SERIES WITH INDUCTORS

The same capacitor C_T is needed to match the time delay between ISEN- and ISEN+ signals. Select the proper C_T to keep the time constant of R_{ISEN} and C_T ($R_{ISEN} \times C_T$) close to 27ns.

Equation 5 shows the ratio of the channel current to the sensed current I_{SEN} .

$$I_{SEN} = I_L \cdot \frac{R_{SENSE}}{R_{ISEN}} \quad (\text{EQ. 5})$$

Current Balance and Current Monitoring

The sensed currents I_A and I_B from each respective channel are summed together and divided by 2. The resulting average current I_{AVG} provides a measure of the total load current. Channel current balance is achieved by comparing the sensed current of each channel to the average current to make an appropriate adjustment to the PWMA and PWMB duty cycle with Intersil's patented current-balance method.

Channel current balance is essential in achieving the thermal advantage of multiphase operation. With good current balance, the power loss is equally dissipated over multiple devices and a greater area.

The resulting average current I_{AVG} also goes out from the IOOUT pin for current monitoring and can also be fed back to the controller's ISEN lines for current balance, load-line regulation, and overcurrent protection. For fast response to the current information, the IOOUT pin should have minimum decoupling; no more than 50ns filter is recommended. The full scale of IOOUT is 100 μ A; it typically should set resistor gain around 50 μ A to 80 μ A at the full load to ensure that it will not hit the full scale prior to the overcurrent trip point. At the same time, the current signal accuracy is maximized.

Benefits of a High Phase Count System

At heavy load condition, efficiency can be improved by spreading the load across many phases. This is primarily because the resistive loss becomes the dominant component of total loss budget at high current levels.

Since the load is carried by more phases, each power device handles less current. In addition, the devices are likely to be spread over a larger area on the Printed Circuit Board (PCB). Both these factors result in improved heat dissipation for higher phase count systems. By reducing the system's operating temperature, the reliability of the components is improved.

Furthermore, increasing the phase count also reduces the size of ripple on both the input and output currents. It reduces EMI and improves the efficiency. [Figures 12](#) and [13](#) show the ripple values for a 24-phase voltage regulator with the following parameters:

- Input voltage: 12V
- Output voltage: 1.6V
- Duty cycle: 13.3%
- Load current: 200A
- Output Phase Inductor: 500nH
- Phase switching frequency: 200kHz

In this example, the 24-phase voltage regulator (VR) can run in 6-phase, 8-phase, 12-phase or 24-phase interleaving mode. In 6-phase interleaving mode, every 4 phases runs synchronously, which yields 18.73A and 12.93A input and output ripple currents, respectively. The 24-phase interleaving regulator significantly drops these values to 4.05A and 0.78A, respectively. As shown in [Table 3](#), both input and output ripple currents are reduced when more phases are running in interleaving mode. Note that the 8-phase VR has lower output ripple current than the 12-phase VR since the 8-phase VR has better output ripple cancellation factor close to the duty cycle of 1/8.

TABLE 3. RIPPLE CURRENT (UNIT: A)

INTERLEAVED PHASES	6	8	12	24
Input Ripple Current	18.73	11.64	8.79	4.05
Output Ripple Current	12.93	2.70	4.83	0.78

[Figure 14](#) shows the efficiency of a 12-phase VR design, which runs the doubler in interleaving and synchronous modes. For comparison, a 6-phase VR with the same number of MOSFETs and inductors is also plotted, clearly demonstrating the efficiency improvement of a high-phase count system and interleaving mode over synchronous mode resulting from the better ripple cancellation.

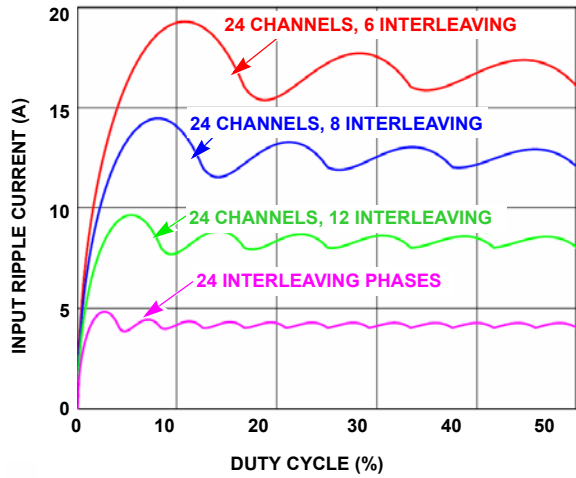

FIGURE 12. INPUT CURRENT RIPPLE vs DUTY CYCLE, PHASE COUNT

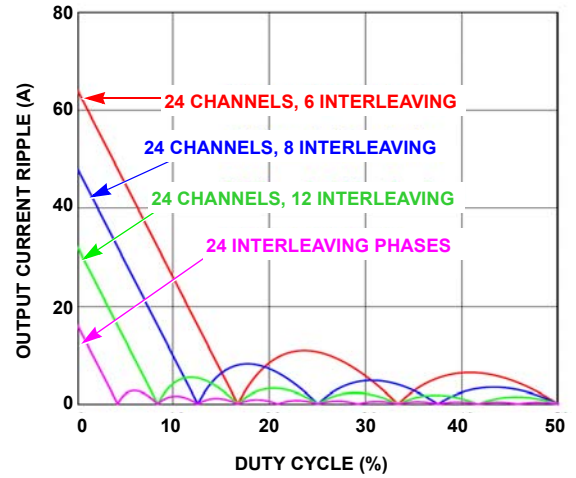

FIGURE 13. OUTPUT CURRENT RIPPLE vs DUTY CYCLE, PHASE COUNT

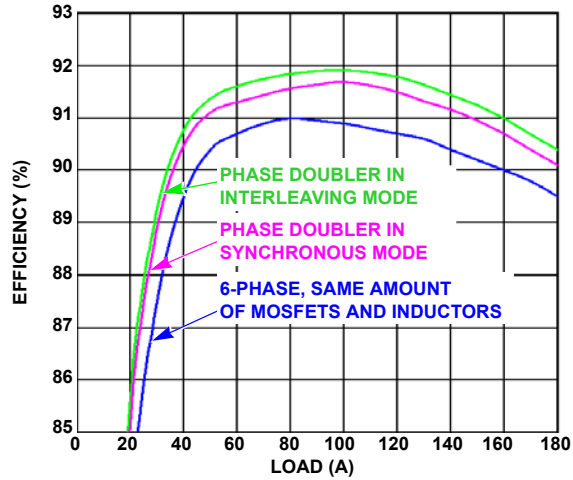

FIGURE 14. EFFICIENCY COMPARISON IN 12-PHASE DESIGN

Revision History

The revision history provided is for informational purposes only and is believed to be accurate, but not warranted. Please go to web to make sure you have the latest Rev.

DATE	REVISION	CHANGE
December 19, 2014	FN7844.0	Initial Release

About Intersil

Intersil Corporation is a leading provider of innovative power management and precision analog solutions. The company's products address some of the largest markets within the industrial and infrastructure, mobile computing and high-end consumer markets.

For the most updated datasheet, application notes, related documentation and related parts, please see the respective product information page found at www.intersil.com.

You may report errors or suggestions for improving this datasheet by visiting www.intersil.com/ask.

Reliability reports are also available from our website at www.intersil.com/support

For additional products, see www.intersil.com/product_tree

Intersil products are manufactured, assembled and tested utilizing ISO9001 quality systems as noted in the quality certifications found at www.intersil.com/design/quality

Intersil products are sold by description only. Intersil Corporation reserves the right to make changes in circuit design, software and/or specifications at any time without notice. Accordingly, the reader is cautioned to verify that data sheets are current before placing orders. Information furnished by Intersil is believed to be accurate and reliable. However, no responsibility is assumed by Intersil or its subsidiaries for its use; nor for any infringements of patents or other rights of third parties which may result from its use. No license is granted by implication or otherwise under any patent or patent rights of Intersil or its subsidiaries.

For information regarding Intersil Corporation and its products, see www.intersil.com

Package Outline Drawing

L10.3x3

10 LEAD DUAL FLAT PACKAGE (DFN)

Rev 10, 7/14

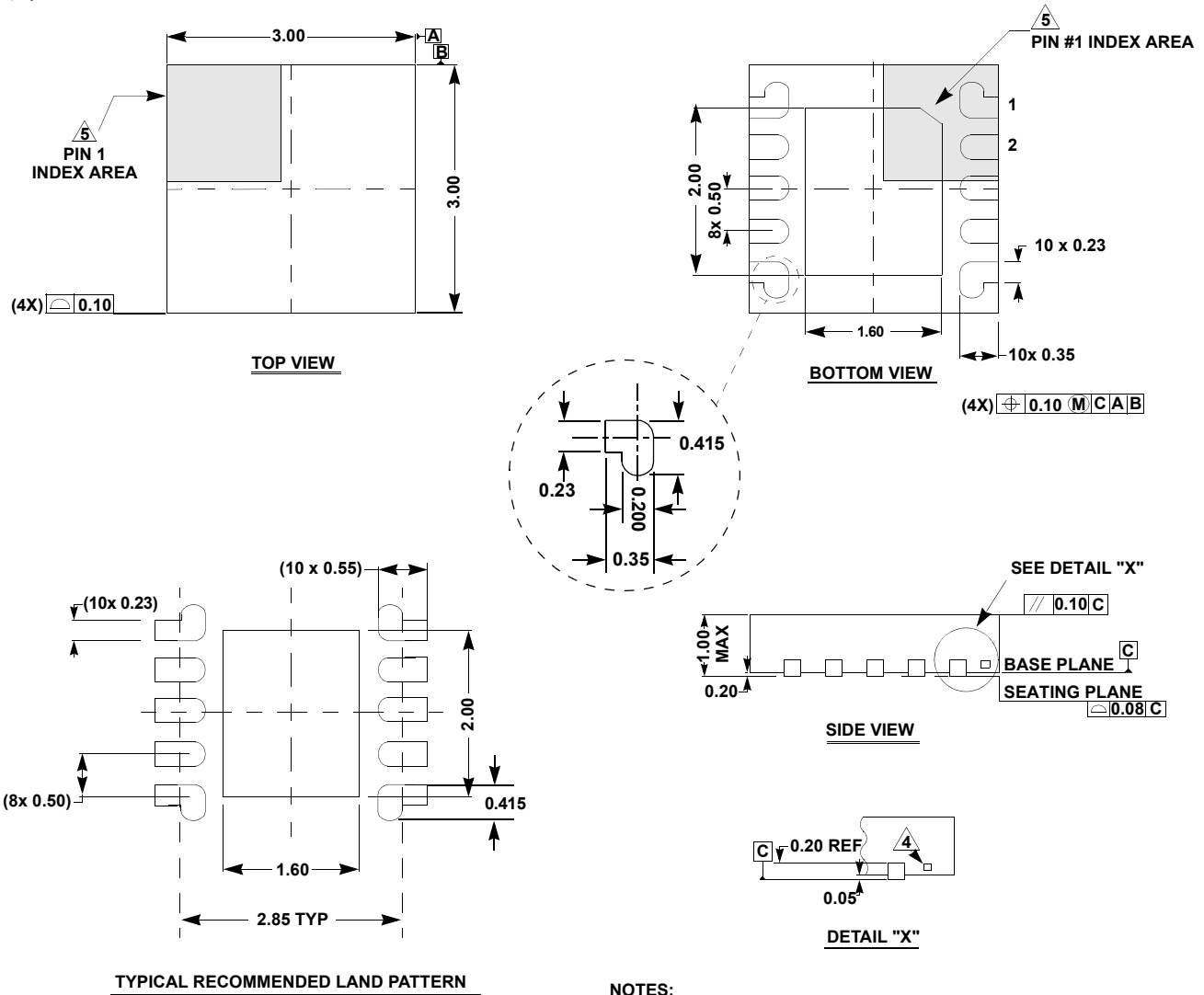

NOTES:

1. Dimensions are in millimeters.
Dimensions in () for Reference Only.
2. Dimensioning and tolerancing conform to ASME Y14.5m-1994.
3. Unless otherwise specified, tolerance : Decimal ± 0.05
4. Tiebar shown (if present) is a non-functional feature.
5. The configuration of the pin #1 identifier is optional, but must be located within the zone indicated. The pin #1 identifier may be either a mold or mark feature.

Mouser Electronics

Authorized Distributor

Click to View Pricing, Inventory, Delivery & Lifecycle Information:

[Intersil:](#)

[ISL6617AFRZ-T](#) [ISL6617AFRZ](#)