



# TJA1052i

## Galvanically isolated high-speed CAN transceiver

Rev. 3 — 19 January 2015

Product data sheet

## 1. General description

---

The TJA1052i is a high-speed CAN transceiver that provides a galvanically isolated interface between a Controller Area Network (CAN) protocol controller and the physical two-wire CAN bus. The TJA1052i is specifically targeted at Electric Vehicles (EV) and Hybrid Electric Vehicles (HEV), where galvanic isolation barriers are needed between the high- and low-voltage parts.

**Safety:** Isolation is required for safety reasons, eg. to protect humans from electric shock or to prevent the electronics being damaged by high voltages.

**Signal integrity:** The isolator uses proprietary capacitive isolation technology to transmit and receive CAN signals. This technology enables more reliable data communications in noisy environments, such as high-voltage battery management systems or the drive and regeneration systems in EVs and HEVs.

**Performance:** The transceiver is designed for high-speed CAN applications in the automotive industry, supplying the differential transmit and receive capability to a CAN protocol controller in a microcontroller. Integrating the galvanic isolation along with the transceiver in the TJA1052i removes the need for stand-alone isolation. It also improves reliability and system performance parameters such as loop delay.

The TJA1052i belongs to the third generation of high-speed CAN transceivers from NXP Semiconductors, offering significant improvements over first- and second-generation devices. It offers improved ElectroMagnetic Compatibility (EMC) and ElectroStatic Discharge (ESD) performance, and also features ideal passive behavior to the CAN bus when the transceiver supply voltage is off.

The TJA1052i implements the CAN physical layer as defined in the current ISO11898 standard (ISO11898-2:2003). Pending the release of the updated version of ISO11898-2 including CAN FD, additional timing parameters defining loop delay symmetry are specified. This implementation enables reliable communication in the CAN FD fast phase at data rates up to 2 Mbit/s.

The TJA1052i is an excellent choice for all types of automotive and industrial CAN networks where isolation is required for safety reasons or to enhance signal integrity in noisy environments.

## 2. Features and benefits

---

### 2.1 General

- Isolator and Transceiver integrated into a single SO16 package, reducing board space
- ISO 11898-2:2003 compliant



- Loop delay symmetry timing enables reliable communication at data rates up to 2 Mbit/s in the CAN FD fast phase
- Flawless cooperation between the Isolator and the Transceiver
  - ◆ Fewer components improves reliability in applications
  - ◆ Guaranteed performance (eg. max loop delay <220 ns)
- Electrical transient immunity of 45 kV/μs (typ)
- AEC-Q100 qualified
- Suitable for use in 12 V and 24 V systems; compatible with 3 V to 5 V microcontrollers
- Bus common mode voltage ( $V_{cm}$ ) = ±25 V
- Low ElectroMagnetic Emission (EME) and high ElectroMagnetic Immunity (EMI)
- Dark green product (halogen free and Restriction of Hazardous Substances (RoHS) compliant)

## 2.2 Power management

- Functional behavior predictable under all supply conditions
- Transceiver disengages from the bus when not powered up (zero load)

## 2.3 Protection

- Up to 5 kV (RMS) rated isolation
- Three versions available (1 kV, 2.5 kV and 5 kV)
- Voltage compliant with UL 1577, IEC 61010 and IEC 60950
- 5 kV (RMS) rated isolation voltage compliant with UL 1577, IEC 61010 and IEC 60950
- Supports ISO6469 'Electrically propelled road vehicles. Safety specifications.'
- High ESD handling capability on the bus pins
- Bus pins protected against transients in automotive environments
- Transmit Data (TXD) dominant time-out function
- Undervoltage detection on supply pins

## 3. Quick reference data

Table 1. Quick reference data

Symbol	Parameter	Conditions	Min	Typ	Max	Unit
I <sub>DD1</sub>	supply current 1	V <sub>TXD</sub> = 0 V; bus dominant	-	-	2.6	mA
		V <sub>TXD</sub> = V <sub>DD1</sub> ; bus recessive	-	-	5.6	mA
I <sub>DD2</sub>	supply current 2	V <sub>TXD</sub> = 0 V; bus dominant; 60 Ω load	-	-	70	mA
		V <sub>TXD</sub> = V <sub>DD1</sub> ; bus recessive	-	-	10	mA
V <sub>uvd(swoff)(VDD2)</sub>	switch-off undervoltage detection voltage on pin V <sub>DD2</sub>		1.3	-	2.7	V
V <sub>ESD</sub>	electrostatic discharge voltage	IEC 61000-4-2 at pins CANH and CANL	-8	-	+8	kV
V <sub>CANH</sub>	voltage on pin CANH		-58	-	+58	V
V <sub>CANL</sub>	voltage on pin CANL		-58	-	+58	V
T <sub>vj</sub>	virtual junction temperature		-40	-	+150	°C
T <sub>amb</sub>	ambient temperature		-40	-	+125	°C

## 4. Ordering information

Table 2. Ordering information

Type number	Package		Version
	Name	Description	
TJA1052iT/5 TJA1052iT/2 TJA1052iT/1	SO16	plastic small outline package; 16 leads; body width 7.5 mm	SOT162-1

Table 3. Voltage ratings

Type number	Rated insulation voltage according to UL 1577, IEC 61010 and IEC 60950
TJA1052iT/5	5 kV (RMS)
TJA1052iT/2	2.5 kV (RMS)
TJA1052iT/1	1 kV (RMS)

## 5. Block diagram

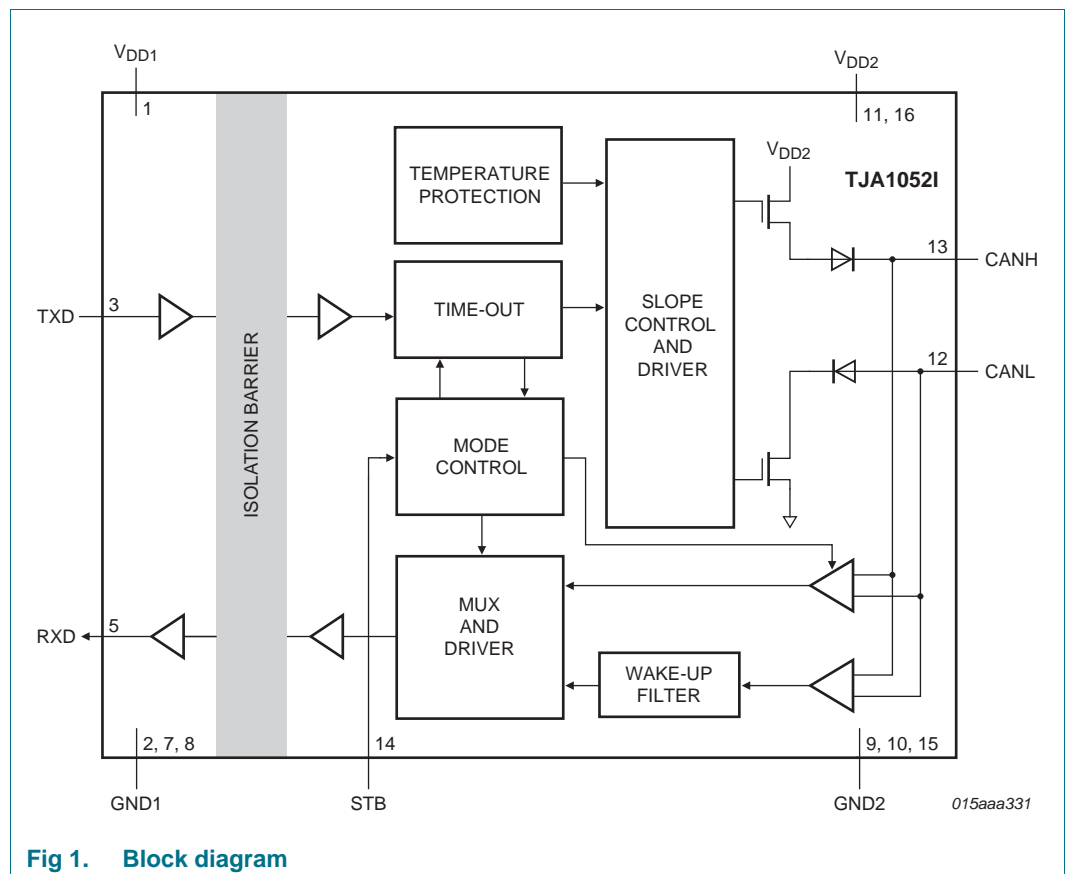
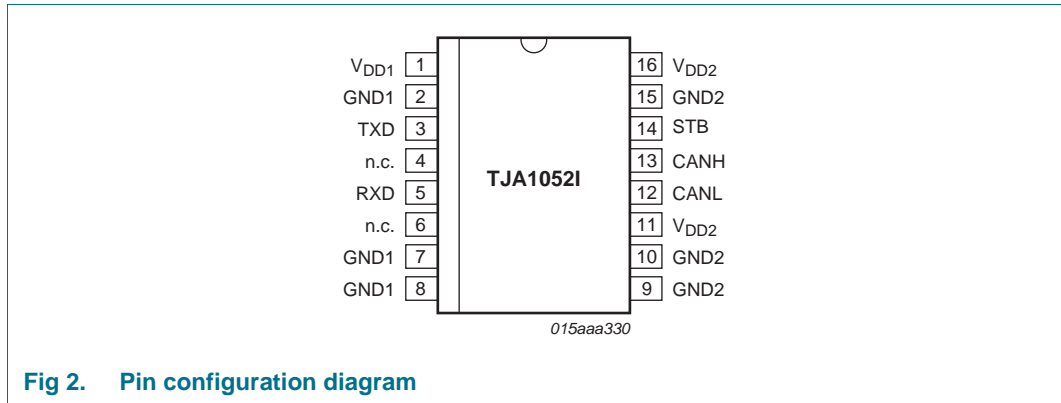

Fig 1. Block diagram

## 6. Pinning information

### 6.1 Pinning



### 6.2 Pin description

**Table 4. Pin description**

Symbol	Pin	Description
V <sub>DD1</sub>	1	supply voltage 1
GND1	2	ground supply 1 <sup>[1]</sup>
TXD	3	transmit data input
n/c	4	not connected
RXD	5	receive data output; reads out data from the bus lines
n/c	6	not connected
GND1	7	ground supply 1 <sup>[1]</sup>
GND1	8	ground supply 1 <sup>[1]</sup>
GND2	9	ground supply 2 <sup>[1]</sup>
GND2	10	ground supply 2 <sup>[1]</sup>
V <sub>DD2</sub>	11	supply voltage 2
CANL	12	LOW-level CAN bus line
CANH	13	HIGH-level CAN bus line
STB	14	Standby mode control input <sup>[2]</sup>
GND2	15	ground supply 2 <sup>[1]</sup>
V <sub>DD2</sub>	16	supply voltage 2

[1] All GND1 pins (pins 2, 7 and 8) should be connected together and to ground domain 1. All GND2 pins (pins 9, 10 and 15) should be connected together and to ground domain 2. Refer to the application notes for further information.

[2] Setting STB HIGH disables the CAN bus connection.

## 7. Functional description

### 7.1 Operation

#### 7.1.1 Normal mode

During normal operation, the TJA1052i transceiver transmits and receives data via bus lines CANH and CANL (see [Figure 1](#) for the block diagram). The differential receiver converts the analog data on the bus lines into digital data, which is output on pin RXD. The slopes of the output signals on the bus lines are controlled internally and are optimized in a way that guarantees the lowest possible EME.

The isolator used in the TJA1052i is an AC device that employs on-off keying to guarantee the DC output state at all times. The states of TXD, RXD and the CAN bus at start-up, shut-down and during normal operation are described in [Table 5](#).

Care should be taken regarding power sequencing if the device is used in networks that support remote wake-up (see [Section 12 “Application information”](#)).

**Table 5. Input/output states at start-up, shut-down and during normal operation**

TXD	RXD	V <sub>DD1</sub>	V <sub>DD2</sub>	CAN	Comments
H	H	>V <sub>uvd</sub> (VDD1)	>V <sub>uvd(stb)</sub> VDD2	recessive	Normal mode operation
L	L	>V <sub>uvd</sub> (VDD1)	>V <sub>uvd(stb)</sub> VDD2	dominant	Normal mode with TXD dominant time-out active
X	X	unpowered	>V <sub>uvd(stb)</sub> VDD2	dominant	dominant after V <sub>DD1</sub> power loss until TXD dominant timeout; recessive while V <sub>DD2</sub> is ramping up from an unpowered state
X	L	>V <sub>uvd</sub> (VDD1)	unpowered	disconnected	RXD transitions L-to-H when V <sub>DD2</sub> restored

#### 7.1.2 Standby mode

Standby mode is provided to improve the response of the TJA1052i to an undervoltage on V<sub>DD2</sub>. The microcontroller cannot switch the transceiver directly to Standby mode. The TJA1052i switches to Standby mode during V<sub>DD2</sub> power-up and power-down. See [Section 7.2.2](#) for a description of undervoltage protection on V<sub>DD2</sub>.

### 7.2 Fail-safe features

#### 7.2.1 TXD dominant time-out function

A ‘TXD dominant time-out’ timer is started when pin TXD goes LOW. If the LOW state on TXD persists for longer than  $t_{to(dom)TXD}$ , the transmitter is disabled, releasing the bus lines to recessive state. This function prevents a hardware and/or software application failure from driving the bus lines to a permanent dominant state (blocking all network communications). The TXD dominant time-out timer is reset by a positive edge on TXD. The TXD dominant time-out time also defines the minimum possible bit rate of 40 kbit/s.

#### 7.2.2 Undervoltage protection: V<sub>DD2</sub>

If the voltage on pin V<sub>DD2</sub> falls below the standby threshold, V<sub>uvd(stb)</sub>(VDD2), the transceiver switches to Standby mode. In Standby mode, the transceiver is not able to transmit or receive data on the bus lines. The transmitter and the Normal mode receiver are switched off and the bus lines are biased to ground to minimize the supply current. The TJA1052i

will remain in Standby mode until  $V_{DD2}$  rises above  $V_{\text{uvd(stb)}}(V_{DD2})$  (max). The low-power receiver continues to monitor the bus while the TJA1052i is in Standby mode. Data on the bus is still reflected onto RXD, but the transfer speed is reduced.

If the voltage on  $V_{DD2}$  falls below the switch-off threshold,  $V_{\text{uvd(swoff)}}(V_{DD2})$ , the transceiver switches off and disengages from the bus (zero load). It is guaranteed to switch on again in Standby mode when  $V_{DD2}$  rises above  $V_{\text{uvd(swoff)}}(V_{DD2})$  (max).

### 7.2.3 Undervoltage protection: $V_{DD1}$

If the voltage on pin  $V_{DD1}$  falls below the undervoltage detection threshold,  $V_{\text{uvd}}(V_{DD1})$ , the CAN bus switches to dominant state and the TXD dominant timeout timer is started. RXD will not go high again until the supply voltage has been restored on  $V_{DD1}$  ( $V_{DD1} > V_{\text{uvd}}(V_{DD1})$ ).

### 7.2.4 Overtemperature protection

The output drivers are protected against overtemperature conditions. If the virtual junction temperature exceeds the shutdown junction temperature,  $T_{j(\text{sd})}$ , the output drivers are disabled. They are enabled again when the virtual junction temperature falls below  $T_{j(\text{sd})}$  and TXD is HIGH. Including the TXD condition ensures that output driver oscillation due to temperature drift is avoided.

## 7.3 Insulation characteristics and safety-related specifications

Table 6. Isolator characteristics

Symbol	Parameter	Conditions	Min	Typ	Max	Unit
$d_{L(I01)}$	minimum air gap		[1] 8.6	-	-	mm
$d_{L(I02)}$	minimum external tracking		[2] 8.1	-	-	mm
$R_{\text{ins}}$	insulation resistance	$T_A = 125\text{ °C}$	[3] 100	-	-	$G\Omega$
		$T_A = 150\text{ °C}$	[3] 10	-	-	$G\Omega$
-	pollution degree	-	2	-	-	-
-	material group (IEC 60664)		2	-	-	-

- [1] Based on the measured data in the package outline.  $d_{L(I01)}$  is the clearance distance. Note that the clearance distance cannot be larger than the creepage distance ( $d_{L(I02)}$ ).
- [2] Based on the measured data in the package outline.  $d_{L(I02)}$  is the creepage distance. According to IEC 60950-1, normative annex F (also IEC60664 chapter 6.2, Example 11), the effective minimum external tracking is 1.0 mm less due to the presence of an intervening, unconnected conductive part.
- [3] Guaranteed by design at a voltage differential of 500 V with the pins on each side of the isolation barrier connected together, simulating a 2-pin device.

**Table 7. Working voltages and isolation**

Insulation Characteristics				
Parameter	Standard	TJA1052i/1	TJA1052i/2	TJA1052i/5
max. working insulation voltage per IEC 60664 ( $V_{IORM}$ ) <sup>[1]</sup>	IEC 60664	300 $V_{RMS}$	450 $V_{RMS}$	800 $V_{RMS}$
		420 $V_{peak}$	630 $V_{peak}$	1120 $V_{peak}$
max. transient overvoltage per IEC 60664 ( $V_{IOTM}$ ) <sup>[2]</sup>	$t_{TEST} = 1.2/50 \mu s$ (certification) IEC 60664	2500 $V_{peak}$	4000 $V_{peak}$	6000 $V_{peak}$
rated insulation voltage per UL 1577 ( $V_{ISO}$ )	UL 1577			
	$t_{TEST} = 60 s$ (qualification)	1000 $V_{RMS}$	2500 $V_{RMS}$	5000 $V_{RMS}$
	$t_{TEST} = 1 s$ (production)	1200 $V_{RMS}$	3000 $V_{RMS}$	6000 $V_{RMS}$
Insulation classification in terms of Overvoltage Category <sup>[3]</sup>				
Insulation type	Max. working voltage	TJA1052i/1	TJA1052i/2	TJA1052i/5
basic insulation <sup>[4]</sup>	$\leq 150 V_{RMS}$	I - III	I - IV	I - IV
	$\leq 300 V_{RMS}$	I - II	I - III	I - IV
	$\leq 600 V_{RMS}$	I	I - II	I - III
	$\leq 1000 V_{RMS}$	-	-	I - II
reinforced insulation <sup>[4]</sup>	$\leq 150 V_{RMS}$	I - II	I - III	I - IV
	$\leq 300 V_{RMS}$	I	I - II	I - III
	$\leq 600 V_{RMS}$	-	I	I - II
	$\leq 1000 V_{RMS}$	-	-	I

- [1] The working voltage is the input-to-output voltage that can be applied without time limit. Which TJA1052i variant should be selected depends on the overvoltage category and the related insulation voltage.
- [2] UL stress test is performed at higher than IEC-specified levels.
- [3] Based on transient overvoltages as indicated in IEC60664; creepage and clearance distances not taken into account.
- [4] Reinforced insulation should have an impulse withstand voltage one step higher than that specified for basic insulation.

**Table 8. Safety approvals**

Standard	File number
IEC 60950	CB NL-33788
IEC 61010-1 2nd Edition	CB NL-33789
UL1577	20131213-E361297

## 8. Limiting values

**Table 9. Limiting values**

In accordance with the Absolute Maximum Rating System (IEC 60134). All voltages and currents are referenced to GND2 unless otherwise specified.

Symbol	Parameter	Conditions	Min	Max	Unit	
V <sub>CANH</sub>	voltage on pin CANH		-58	+58	V	
V <sub>CANL</sub>	voltage on pin CANL		-58	+58	V	
V <sub>DD1</sub>	supply voltage 1		[1] -0.3	+6.0	V	
V <sub>DD2</sub>	supply voltage 2		-0.3	+6.0	V	
V <sub>I</sub>	input voltage	on pin TXD	[1] -0.3	V <sub>DD1</sub> + 0.3	V	
V <sub>O</sub>	output voltage	on pin RXD	[1] -0.3	V <sub>DD1</sub> + 0.3	V	
I <sub>O</sub>	output current	on pin RXD	[1] -	10	mA	
V <sub>trt</sub>	transient voltage	on pins CANH and CANL		-150	+100	V
V <sub>ESD</sub>	electrostatic discharge voltage	IEC 61000-4-2 (150 pF, 330 Ω)	[2]			
		at pins CANH and CANL		-8	+8	kV
		Human Body Model (HBM); 100 pF, 1.5 kΩ	[3]			
		at pins CANH and CANL	[4]	-8	+8	kV
		at any other pin		-4	+4	kV
		Machine Model (MM); 200 pF, 0.75 μH, 10 Ω	[5]			
		at any pin		-300	+300	V
		Charged Device Model (CDM); field Induced charge; 4 pF	[6]			
	at corner pins		-750	+750	V	
	at any pin		-500	+500	V	
T <sub>vj</sub>	virtual junction temperature		[7] -40	+150	°C	
T <sub>amb</sub>	ambient temperature		-40	+125	°C	
T <sub>stg</sub>	storage temperature		[8] -65	+150	°C	

[1] Referenced to GND1.

[2] According to IEC TS 62228 (2007), Section 4.3; DIN EN 61000-4-2.

[3] According to AEC-Q100-002.

[4] ±8 kV to GND2 and V<sub>DD2</sub>; ±6 kV to GND1.

[5] According to AEC-Q100-003.

[6] According to AEC-Q100-011 Rev-C1. The classification level is C4B.

[7] An alternative definition of virtual junction temperature is:  $T_{vj} = T_{amb} + P \times R_{th(vj-a)}$ , where  $R_{th(vj-a)}$  is a fixed value used in the calculation of  $T_{vj}$ . The rating for  $T_{vj}$  limits the allowable combinations of power dissipation (P) and ambient temperature ( $T_{amb}$ ).

[8] If UL compliance is required, the maximum storage temperature is limited to 130 °C.

## 9. Thermal characteristics

**Table 10. Thermal characteristics**

According to IEC 60747-1.

Symbol	Parameter	Conditions	Value	Unit
R <sub>th(vj-a)</sub>	thermal resistance from virtual junction to ambient	in free air	100	K/W



## 10. Static characteristics

**Table 11. Static characteristics**

$T_{vj} = -40\text{ }^{\circ}\text{C}$  to  $+150\text{ }^{\circ}\text{C}$ ;  $V_{DD1} = 3.0\text{ V}$  to  $5.25\text{ V}$ ;  $V_{DD2} = 4.75\text{ V}$  to  $5.25\text{ V}$  unless otherwise specified. Positive currents flow into the IC. All voltages and currents are referenced to GND2 unless otherwise specified<sup>[1]</sup>.

Symbol	Parameter	Conditions	Min	Typ	Max	Unit	
<b>DC supplies; pin V<sub>DD1</sub> and V<sub>DD2</sub></b>							
I <sub>DD1</sub>	supply current 1	V <sub>DD1</sub> = 3 V to 5 V; V <sub>DD2</sub> = 5 V; V <sub>TXD</sub> = 0 V; bus dominant	[2]	-	-	2.6	mA
		V <sub>DD1</sub> = 3 V to 5 V; V <sub>DD2</sub> = 5 V; V <sub>TXD</sub> = V <sub>DD1</sub> ; bus recessive	[2]	-	-	5.6	mA
I <sub>DD2</sub>	supply current 2	V <sub>DD1</sub> = 3 V to 5 V; V <sub>DD2</sub> = 5 V; V <sub>TXD</sub> = 0 V; bus dominant; R <sub>L</sub> = 60 Ω		-	-	70	mA
		V <sub>DD1</sub> = 3 V to 5 V; V <sub>DD2</sub> = 5 V; V <sub>TXD</sub> = V <sub>DD1</sub> ; bus recessive		-	-	10	mA
V <sub>uvd(stb)(VDD2)</sub>	standby undervoltage detection voltage on pin V <sub>DD2</sub>		3.5	-	4.75	V	
V <sub>uvd(swoff)(VDD2)</sub>	switch-off undervoltage detection voltage on pin V <sub>DD2</sub>		1.3	-	2.7	V	
V <sub>uvd(VDD1)</sub>	undervoltage detection voltage on pin V <sub>DD1</sub>		[2] 1.3	-	2.7	V	
V <sub>uvhys</sub>	undervoltage hysteresis voltage	on pin V <sub>DD1</sub>	[2] 40	-	100	mV	
		on pin V <sub>DD2</sub>	80	-	200	mV	
<b>CAN transmit data input; pin TXD</b>							
V <sub>IH</sub>	HIGH-level input voltage		[2] 2.0	-	V <sub>DD1</sub>	V	
V <sub>IL</sub>	LOW-level input voltage		[2] 0	-	0.8	V	
I <sub>LI</sub>	input leakage current		[2] -10	-	+10	μA	
<b>CAN receive data output; pin RXD</b>							
V <sub>OH</sub>	HIGH-level output voltage	I <sub>OH</sub> = -4 mA	[2] V <sub>DD1</sub> - 0.4	-	-	V	
V <sub>OL</sub>	LOW-level output voltage	I <sub>OL</sub> = 4 mA	[2] -	-	0.4	V	
<b>Standby mode control input; pin STB</b>							
V <sub>IH</sub>	HIGH-level input voltage		0.7V <sub>CC</sub>	-	V <sub>CC</sub> + 0.3	V	
V <sub>IL</sub>	LOW-level input voltage		-0.3	-	0.3V <sub>CC</sub>	V	
I <sub>IH</sub>	HIGH-level input current	V <sub>STB</sub> = V <sub>CC</sub>	-1	-	+1	μA	
I <sub>IL</sub>	LOW-level input current	V <sub>STB</sub> = 0 V	-15	-	-1	μA	
<b>Bus lines; pins CANH and CANL</b>							
V <sub>O(dom)</sub>	dominant output voltage	V <sub>TXD</sub> = 0 V; t < t <sub>to(dom)TXD</sub>					
		pin CANH	2.75	3.5	4.5	V	
		pin CANL	0.5	1.5	2.25	V	
V <sub>dom(TX)sym</sub>	transmitter dominant voltage symmetry	V <sub>dom(TX)sym</sub> = V <sub>CC</sub> - V <sub>CANH</sub> - V <sub>CANL</sub>	-400	-	+400	mV	

**Table 11. Static characteristics ...continued**

$T_{vj} = -40\text{ }^{\circ}\text{C}$  to  $+150\text{ }^{\circ}\text{C}$ ;  $V_{DD1} = 3.0\text{ V}$  to  $5.25\text{ V}$ ;  $V_{DD2} = 4.75\text{ V}$  to  $5.25\text{ V}$  unless otherwise specified. Positive currents flow into the IC. All voltages and currents are referenced to GND2 unless otherwise specified<sup>[1]</sup>.

Symbol	Parameter	Conditions	Min	Typ	Max	Unit
$V_{O(\text{dif})\text{bus}}$	bus differential output voltage	$V_{\text{TXD}} = 0\text{ V}$ ; $t < t_{\text{to}(\text{dom})\text{TXD}}$ $R_L = 45\ \Omega$ to $65\ \Omega$	1.5	-	3	V
		$V_{\text{TXD}} = V_{\text{CC}}$ recessive; no load	-50	-	+50	mV
$V_{O(\text{rec})}$	recessive output voltage	Normal mode; $V_{\text{TXD}} = V_{\text{CC}}$ ; no load	2	$0.5V_{\text{CC}}$	3	V
$V_{\text{th}(\text{RX})\text{dif}}$	differential receiver threshold voltage	$V_{\text{cm}(\text{CAN})} = -25\text{ V}$ to $+25\text{ V}$ <sup>[3]</sup>				
		Normal mode	0.5	-	0.9	V
		Standby mode; $V_{\text{cm}(\text{CAN})} = -12\text{ V}$ to $+12\text{ V}$ <sup>[4]</sup>	0.4	-	1.15	V
$V_{\text{hys}(\text{RX})\text{dif}}$	differential receiver hysteresis voltage	$V_{\text{cm}(\text{CAN})} = -25\text{ V}$ to $+25\text{ V}$ Normal mode	-	165	-	mV
$I_{O(\text{sc})\text{dom}}$	dominant short-circuit output current	$V_{\text{TXD}} = 0\text{ V}$ ; $t < t_{\text{to}(\text{dom})\text{TXD}}$ ; $V_{\text{DD2}} = 5\text{ V}$				
		pin CANH; $V_{\text{CANH}} = 0\text{ V}$	-100	-70	-40	mA
		pin CANL; $V_{\text{CANL}} = 5\text{ V} / 40\text{ V}$	40	70	100	mA
$I_{O(\text{sc})\text{rec}}$	recessive short-circuit output current	Normal mode; $V_{\text{TXD}} = V_{\text{DD1}}$ $V_{\text{CANH}} = V_{\text{CANL}} = -27\text{ V}$ to $+32\text{ V}$	-5	-	+5	mA
$I_L$	leakage current	$V_{\text{DD2}} = 0\text{ V}$ ; $V_{\text{CANH}} = V_{\text{CANL}} = 5\text{ V}$	-3	-	+3	$\mu\text{A}$
$R_i$	input resistance		9	15	28	$\text{k}\Omega$
$\Delta R_i$	input resistance deviation	between $V_{\text{CANH}}$ and $V_{\text{CANL}}$	-3	-	+3	%
$R_{i(\text{dif})}$	differential input resistance		19	30	52	$\text{k}\Omega$
$C_{i(\text{cm})}$	common-mode input capacitance		<sup>[5]</sup> -	-	20	pF
$C_{i(\text{dif})}$	differential input capacitance		<sup>[5]</sup> -	-	10	pF
<b>Temperature detection</b>						
$T_{j(\text{sd})}$	shutdown junction temperature		<sup>[5]</sup> - <sup>[6]</sup>	190	-	$^{\circ}\text{C}$

[1] All parameters are guaranteed over the virtual junction temperature range by design. Factory testing uses correlated test conditions to cover the specified temperature and power supply voltage range.

[2] Referenced to GND1.

[3]  $V_{\text{cm}(\text{CAN})}$  is the common mode voltage of CANH and CANL.

[4] Standby mode entered when  $V_{\text{DD2}}$  falls below  $V_{\text{uvd}(\text{stb})}(V_{\text{DD2}})$ .

[5] Not tested in production; guaranteed by design.

[6] RXD is LOW during thermal shutdown.

## 11. Dynamic characteristics

**Table 12. Dynamic characteristics**

$T_{vj} = -40\text{ °C to }+150\text{ °C}$ ;  $V_{DD1} = 3.0\text{ V to }5.25\text{ V}$ ;  $V_{DD2} = 4.75\text{ V to }5.25\text{ V unless otherwise specified}$ <sup>[1]</sup>.

Symbol	Parameter	Conditions	Min	Typ	Max	Unit
<b>Transceiver timing; pins CANH, CANL, TXD and RXD; see Figure 3</b>						
$t_{d(\text{TXD-busdom})}$	delay time from TXD to bus dominant	Normal mode	-	72	120	ns
$t_{d(\text{TXD-busrec})}$	delay time from TXD to bus recessive	Normal mode	-	97	120	ns
$t_{d(\text{busdom-RXD})}$	delay time from bus dominant to RXD	Normal mode	-	67	130	ns
$t_{d(\text{busrec-RXD})}$	delay time from bus recessive to RXD	Normal mode	-	72	130	ns
$t_{PD(\text{TXD-RXD})}$	propagation delay from TXD to RXD	Normal mode	72	-	220	ns
$t_{bit(\text{RXD})}$	bit time on pin RXD	$t_{bit(\text{TXD})} = 500\text{ ns}$ <sup>[2]</sup>	400	-	550	ns
$t_{to(\text{dom})\text{TXD}}$	TXD dominant time-out time	$V_{\text{TXD}} = 0\text{ V}$ ; Normal mode	0.3	1.7	5	ms
CMTI	common-mode transient immunity	$V_I = V_{DD1}$ or $V_I = 0\text{ V}$ <sup>[3]</sup>	20	45	-	kV/ $\mu\text{s}$
$t_{\text{startup}}$	start-up time	<sup>[4]</sup>	-	-	500	$\mu\text{s}$

[1] All parameters are guaranteed over the virtual junction temperature range by design. Factory testing uses correlated test conditions to cover the specified temperature and power supply voltage range.

[2] See Figure 4.

[3] See Figure 6.

[4] The start-up time is the time from the application of power to valid data at the output. Guaranteed by design.

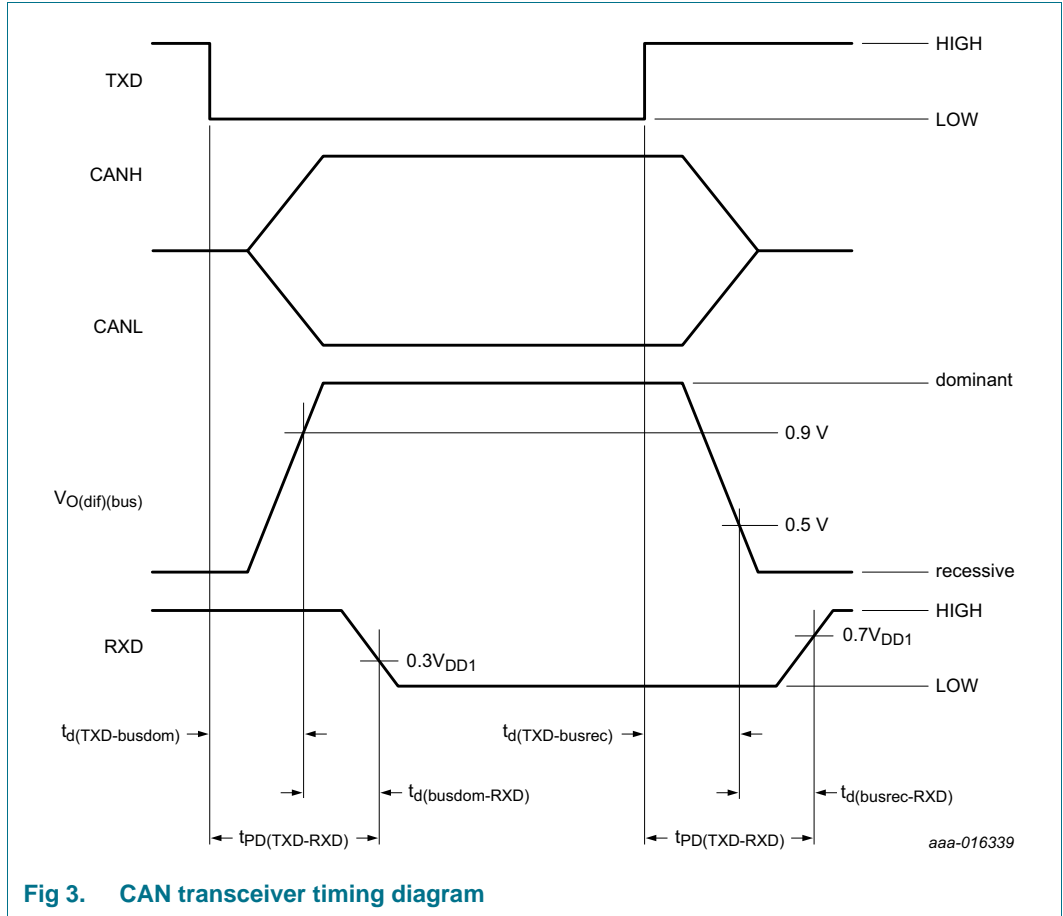

Fig 3. CAN transceiver timing diagram

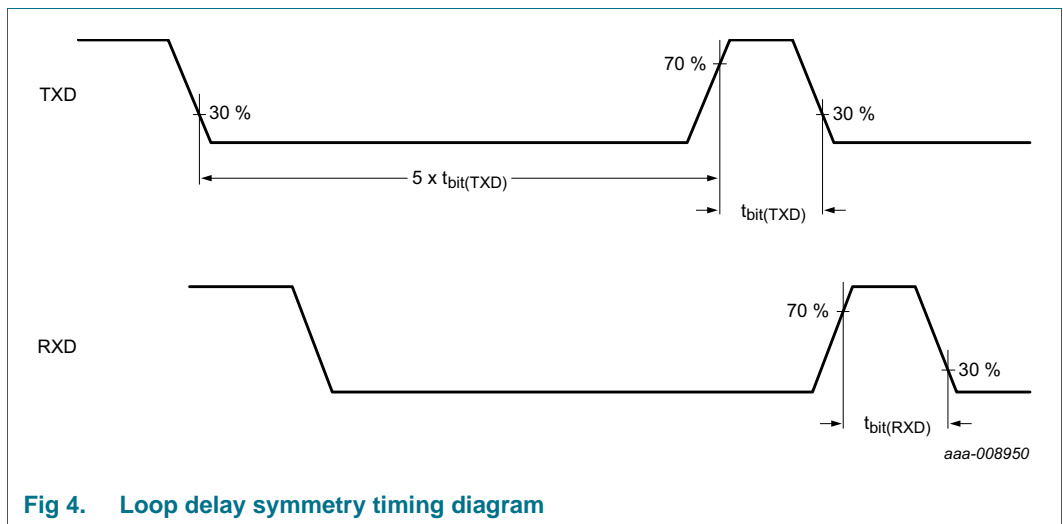

Fig 4. Loop delay symmetry timing diagram

## 12. Application information

Isolated CAN applications are becoming increasingly common in electric and hybrid electric vehicles. The TJA1052i is the ideal solution in applications that require an isolated CAN node, such as Li-ion battery management, regenerative braking and 48 V-to-12 V level shifting. The device can also be used to isolate high-voltage on-demand pumps and motors in belt elimination projects.

If the TJA1052i is used in a HS-CAN network that supports remote bus wake-up, the power-down sequence of the supplies must be managed properly to avoid a dominant pulse on the CAN bus.  $V_{DD2}$  should pass the minimum undervoltage threshold ( $V_{uvd(stb)}(V_{DD2})$  (min)) before  $V_{DD1}$  falls below its maximum undervoltage detection threshold ( $V_{uvd}(V_{DD1})(max)$ ). Power-up sequencing can happen in any order.

Digital inputs and outputs are 3 V compliant, allowing the TJA1052i to interface directly with 3 V and 5 V microcontrollers.

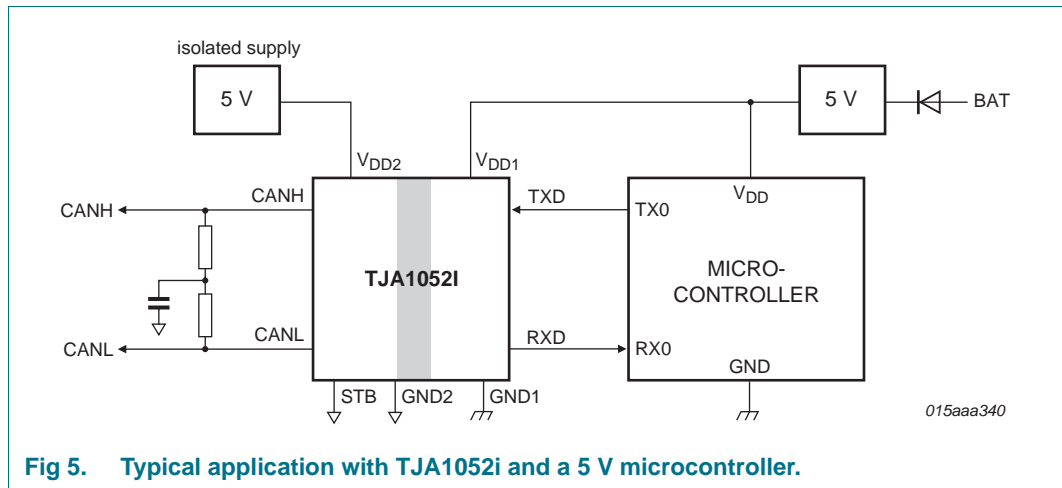

Fig 5. Typical application with TJA1052i and a 5 V microcontroller.

### 12.1 Application hints

Further information on the application of the TJA1052i can be found in NXP application hints *AH1301 Application Hints - TJA1052i Galvanic Isolated High Speed CAN Transceiver*.

## 13. Test information

### 13.1 Quality information

This product has been qualified in accordance with the Automotive Electronics Council (AEC) standard *Q100 Rev-G - Failure mechanism based stress test qualification for integrated circuits*, and is suitable for use in automotive applications.

13.2 Test circuits

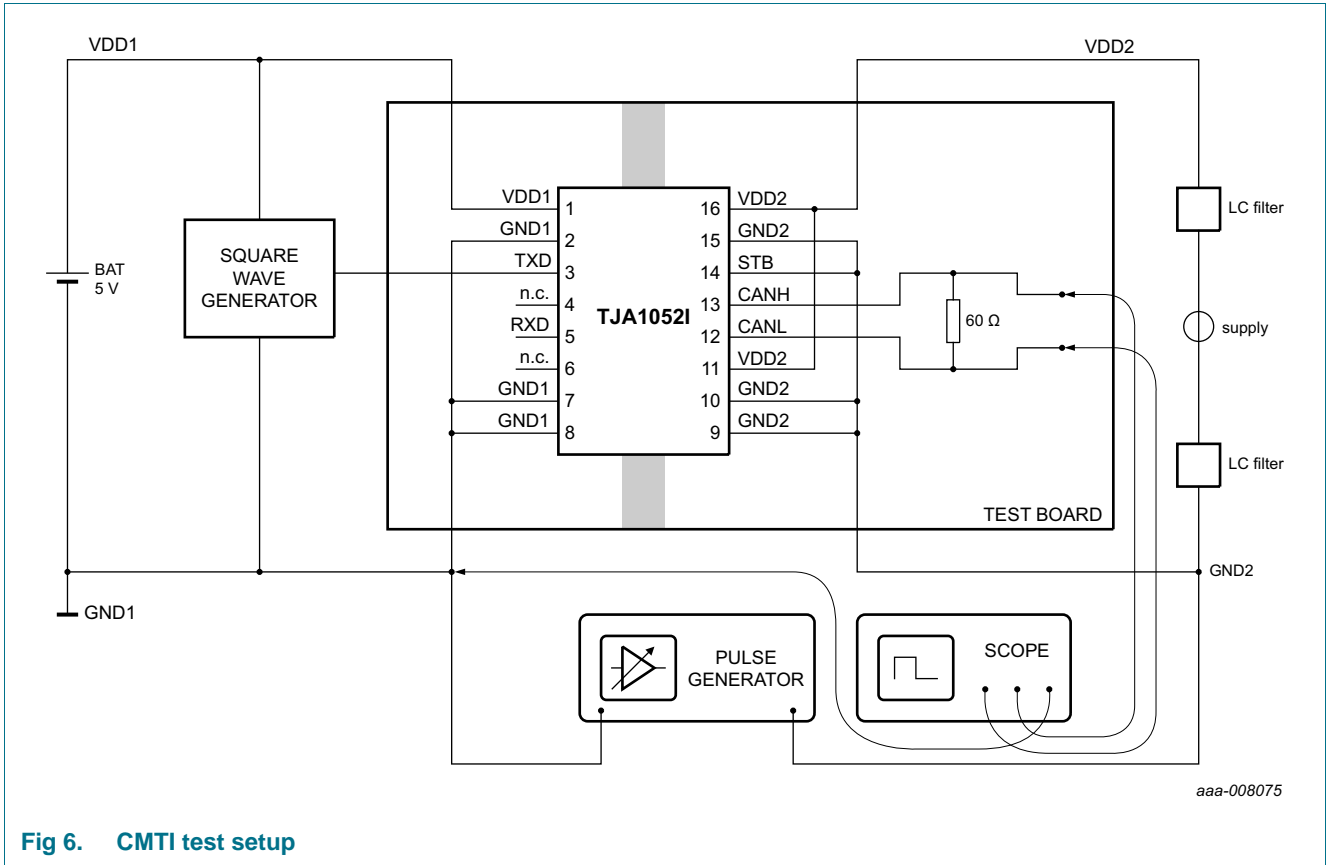

Fig 6. CMTI test setup

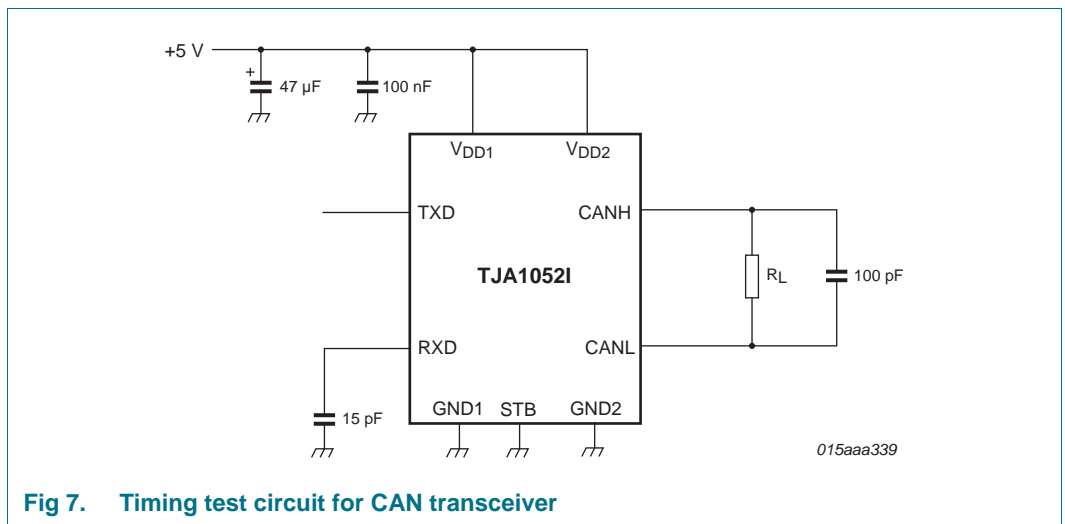

Fig 7. Timing test circuit for CAN transceiver

### 14. Package outline

SO16: plastic small outline package; 16 leads; body width 7.5 mm

SOT162-1

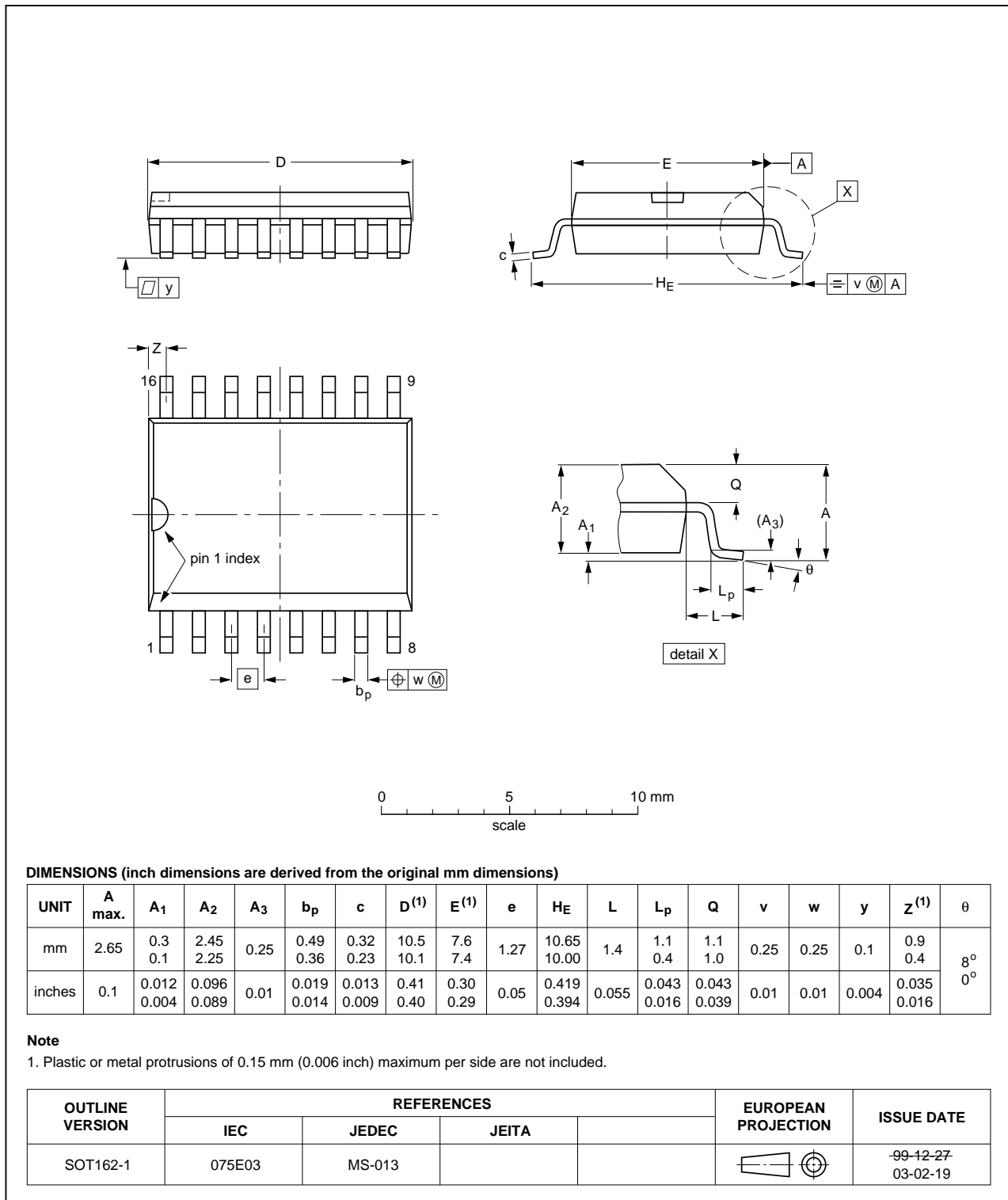

Fig 8. Package outline SOT162-1 (SO16)

## 15. Handling information

All input and output pins are protected against ElectroStatic Discharge (ESD) under normal handling. When handling ensure that the appropriate precautions are taken as described in *JESD625-A* or equivalent standards.

## 16. Soldering of SMD packages

This text provides a very brief insight into a complex technology. A more in-depth account of soldering ICs can be found in Application Note *AN10365 "Surface mount reflow soldering description"*.

### 16.1 Introduction to soldering

Soldering is one of the most common methods through which packages are attached to Printed Circuit Boards (PCBs), to form electrical circuits. The soldered joint provides both the mechanical and the electrical connection. There is no single soldering method that is ideal for all IC packages. Wave soldering is often preferred when through-hole and Surface Mount Devices (SMDs) are mixed on one printed wiring board; however, it is not suitable for fine pitch SMDs. Reflow soldering is ideal for the small pitches and high densities that come with increased miniaturization.

### 16.2 Wave and reflow soldering

Wave soldering is a joining technology in which the joints are made by solder coming from a standing wave of liquid solder. The wave soldering process is suitable for the following:

- Through-hole components
- Leaded or leadless SMDs, which are glued to the surface of the printed circuit board

Not all SMDs can be wave soldered. Packages with solder balls, and some leadless packages which have solder lands underneath the body, cannot be wave soldered. Also, leaded SMDs with leads having a pitch smaller than ~0.6 mm cannot be wave soldered, due to an increased probability of bridging.

The reflow soldering process involves applying solder paste to a board, followed by component placement and exposure to a temperature profile. Leaded packages, packages with solder balls, and leadless packages are all reflow solderable.

Key characteristics in both wave and reflow soldering are:

- Board specifications, including the board finish, solder masks and vias
- Package footprints, including solder thieves and orientation
- The moisture sensitivity level of the packages
- Package placement
- Inspection and repair
- Lead-free soldering versus SnPb soldering

### 16.3 Wave soldering

Key characteristics in wave soldering are:



- Process issues, such as application of adhesive and flux, clinching of leads, board transport, the solder wave parameters, and the time during which components are exposed to the wave
- Solder bath specifications, including temperature and impurities

### 16.4 Reflow soldering

Key characteristics in reflow soldering are:

- Lead-free versus SnPb soldering; note that a lead-free reflow process usually leads to higher minimum peak temperatures (see [Figure 9](#)) than a SnPb process, thus reducing the process window
- Solder paste printing issues including smearing, release, and adjusting the process window for a mix of large and small components on one board
- Reflow temperature profile; this profile includes preheat, reflow (in which the board is heated to the peak temperature) and cooling down. It is imperative that the peak temperature is high enough for the solder to make reliable solder joints (a solder paste characteristic). In addition, the peak temperature must be low enough that the packages and/or boards are not damaged. The peak temperature of the package depends on package thickness and volume and is classified in accordance with [Table 13](#) and [14](#)

**Table 13. SnPb eutectic process (from J-STD-020D)**

Package thickness (mm)	Package reflow temperature (°C)	
	Volume (mm <sup>3</sup> )	
	< 350	≥ 350
< 2.5	235	220
≥ 2.5	220	220

**Table 14. Lead-free process (from J-STD-020D)**

Package thickness (mm)	Package reflow temperature (°C)		
	Volume (mm <sup>3</sup> )		
	< 350	350 to 2000	> 2000
< 1.6	260	260	260
1.6 to 2.5	260	250	245
> 2.5	250	245	245

Moisture sensitivity precautions, as indicated on the packing, must be respected at all times.

Studies have shown that small packages reach higher temperatures during reflow soldering, see [Figure 9](#).

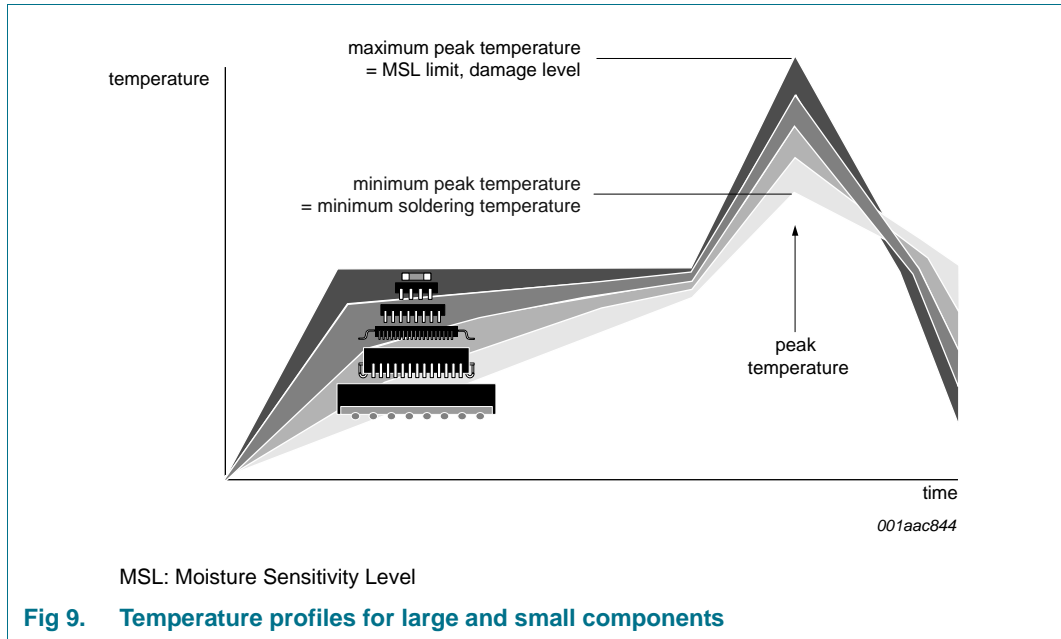

For further information on temperature profiles, refer to Application Note AN10365 “Surface mount reflow soldering description”.

## 17. Revision history

Table 15. Revision history

Document ID	Release date	Data sheet status	Change notice	Supersedes
TJA1052i v.3	20150119	Product data sheet	-	TJA1052i v.2
Modifications:	<ul style="list-style-type: none"> <li>• <a href="#">Section 1</a>: text revised (4th paragraph); paragraph added</li> <li>• <a href="#">Section 2</a>: minor amendments to text</li> <li>• <a href="#">Section 2.1</a>: features added</li> <li>• UL1577 certification added (<a href="#">Section 2.3</a> third bullet; <a href="#">Table 8</a> file number added)</li> <li>• <a href="#">Table 1</a>, <a href="#">Table 9</a>: measurements conditions changed (<math>V_{CANH}</math>, <math>V_{CANL}</math>)</li> <li>• <a href="#">Section 7.1.1</a>: minor changes to text</li> <li>• <a href="#">Table 6</a>: measurement conditions changed: <math>R_{ins}</math>; <a href="#">Table note 3</a> revised</li> <li>• <a href="#">Table 8</a>: file numbers updated</li> <li>• <a href="#">Table 9</a>: measurements conditions changed: <math>V_{ESD}</math>; table note section revised</li> <li>• <a href="#">Table 11</a>: <a href="#">Table note 1</a> added along with references to <a href="#">Table note 2</a>; <a href="#">Table note 5</a> amended; parameters renamed: <math>I_{O(sc)dom}</math> and <math>I_{O(sc)rec}</math></li> <li>• <a href="#">Table 12</a>: parameter <math>t_{bit(RXD)}</math> added; <a href="#">Table note 1</a>, <a href="#">Table note 2</a> and <a href="#">Figure 4</a> added; parameter <math>f_{data}</math> deleted</li> <li>• <a href="#">Figure 3</a>, <a href="#">Figure 6</a> amended</li> <li>• <a href="#">Section 12.1 “Application hints”</a>: added</li> <li>• <a href="#">Section 18.3</a>: ‘Translations’ disclaimer added</li> </ul>			
TJA1052i v.2	20130712	Product data sheet	-	TJA1052i v.1
TJA1052i v.1	20130424	Product data sheet	-	-

## 18. Legal information

### 18.1 Data sheet status

Document status <sup>[1][2]</sup>	Product status <sup>[3]</sup>	Definition
Objective [short] data sheet	Development	This document contains data from the objective specification for product development.
Preliminary [short] data sheet	Qualification	This document contains data from the preliminary specification.
Product [short] data sheet	Production	This document contains the product specification.

[1] Please consult the most recently issued document before initiating or completing a design.

[2] The term 'short data sheet' is explained in section "Definitions".

[3] The product status of device(s) described in this document may have changed since this document was published and may differ in case of multiple devices. The latest product status information is available on the Internet at URL <http://www.nxp.com>.

### 18.2 Definitions

**Draft** — The document is a draft version only. The content is still under internal review and subject to formal approval, which may result in modifications or additions. NXP Semiconductors does not give any representations or warranties as to the accuracy or completeness of information included herein and shall have no liability for the consequences of use of such information.

**Short data sheet** — A short data sheet is an extract from a full data sheet with the same product type number(s) and title. A short data sheet is intended for quick reference only and should not be relied upon to contain detailed and full information. For detailed and full information see the relevant full data sheet, which is available on request via the local NXP Semiconductors sales office. In case of any inconsistency or conflict with the short data sheet, the full data sheet shall prevail.

**Product specification** — The information and data provided in a Product data sheet shall define the specification of the product as agreed between NXP Semiconductors and its customer, unless NXP Semiconductors and customer have explicitly agreed otherwise in writing. In no event however, shall an agreement be valid in which the NXP Semiconductors product is deemed to offer functions and qualities beyond those described in the Product data sheet.

### 18.3 Disclaimers

**Limited warranty and liability** — Information in this document is believed to be accurate and reliable. However, NXP Semiconductors does not give any representations or warranties, expressed or implied, as to the accuracy or completeness of such information and shall have no liability for the consequences of use of such information. NXP Semiconductors takes no responsibility for the content in this document if provided by an information source outside of NXP Semiconductors.

In no event shall NXP Semiconductors be liable for any indirect, incidental, punitive, special or consequential damages (including - without limitation - lost profits, lost savings, business interruption, costs related to the removal or replacement of any products or rework charges) whether or not such damages are based on tort (including negligence), warranty, breach of contract or any other legal theory.

Notwithstanding any damages that customer might incur for any reason whatsoever, NXP Semiconductors' aggregate and cumulative liability towards customer for the products described herein shall be limited in accordance with the *Terms and conditions of commercial sale* of NXP Semiconductors.

**Right to make changes** — NXP Semiconductors reserves the right to make changes to information published in this document, including without limitation specifications and product descriptions, at any time and without notice. This document supersedes and replaces all information supplied prior to the publication hereof.

**Suitability for use in automotive applications** — This NXP Semiconductors product has been qualified for use in automotive applications. Unless otherwise agreed in writing, the product is not designed, authorized or warranted to be suitable for use in life support, life-critical or safety-critical systems or equipment, nor in applications where failure or malfunction of an NXP Semiconductors product can reasonably be expected to result in personal injury, death or severe property or environmental damage. NXP Semiconductors and its suppliers accept no liability for inclusion and/or use of NXP Semiconductors products in such equipment or applications and therefore such inclusion and/or use is at the customer's own risk.

**Applications** — Applications that are described herein for any of these products are for illustrative purposes only. NXP Semiconductors makes no representation or warranty that such applications will be suitable for the specified use without further testing or modification.

Customers are responsible for the design and operation of their applications and products using NXP Semiconductors products, and NXP Semiconductors accepts no liability for any assistance with applications or customer product design. It is customer's sole responsibility to determine whether the NXP Semiconductors product is suitable and fit for the customer's applications and products planned, as well as for the planned application and use of customer's third party customer(s). Customers should provide appropriate design and operating safeguards to minimize the risks associated with their applications and products.

NXP Semiconductors does not accept any liability related to any default, damage, costs or problem which is based on any weakness or default in the customer's applications or products, or the application or use by customer's third party customer(s). Customer is responsible for doing all necessary testing for the customer's applications and products using NXP Semiconductors products in order to avoid a default of the applications and the products or of the application or use by customer's third party customer(s). NXP does not accept any liability in this respect.

**Limiting values** — Stress above one or more limiting values (as defined in the Absolute Maximum Ratings System of IEC 60134) will cause permanent damage to the device. Limiting values are stress ratings only and (proper) operation of the device at these or any other conditions above those given in the Recommended operating conditions section (if present) or the Characteristics sections of this document is not warranted. Constant or repeated exposure to limiting values will permanently and irreversibly affect the quality and reliability of the device.

**Terms and conditions of commercial sale** — NXP Semiconductors products are sold subject to the general terms and conditions of commercial sale, as published at <http://www.nxp.com/profile/terms>, unless otherwise agreed in a valid written individual agreement. In case an individual agreement is concluded only the terms and conditions of the respective agreement shall apply. NXP Semiconductors hereby expressly objects to applying the customer's general terms and conditions with regard to the purchase of NXP Semiconductors products by customer.

**No offer to sell or license** — Nothing in this document may be interpreted or construed as an offer to sell products that is open for acceptance or the grant, conveyance or implication of any license under any copyrights, patents or other industrial or intellectual property rights.

**Export control** — This document as well as the item(s) described herein may be subject to export control regulations. Export might require a prior authorization from competent authorities.

**Quick reference data** — The Quick reference data is an extract of the product data given in the Limiting values and Characteristics sections of this document, and as such is not complete, exhaustive or legally binding.

**Translations** — A non-English (translated) version of a document is for reference only. The English version shall prevail in case of any discrepancy between the translated and English versions.

## 18.4 Trademarks

Notice: All referenced brands, product names, service names and trademarks are the property of their respective owners.

## 19. Contact information

---

For more information, please visit: <http://www.nxp.com>

For sales office addresses, please send an email to: [salesaddresses@nxp.com](mailto:salesaddresses@nxp.com)

## 20. Contents

<b>1</b>	<b>General description</b> .....	<b>1</b>	<b>19</b>	<b>Contact information</b> .....	<b>20</b>
<b>2</b>	<b>Features and benefits</b> .....	<b>1</b>	<b>20</b>	<b>Contents</b> .....	<b>21</b>
2.1	General .....	1			
2.2	Power management .....	2			
2.3	Protection .....	2			
<b>3</b>	<b>Quick reference data</b> .....	<b>2</b>			
<b>4</b>	<b>Ordering information</b> .....	<b>3</b>			
<b>5</b>	<b>Block diagram</b> .....	<b>3</b>			
<b>6</b>	<b>Pinning information</b> .....	<b>4</b>			
6.1	Pinning .....	4			
6.2	Pin description .....	4			
<b>7</b>	<b>Functional description</b> .....	<b>5</b>			
7.1	Operation .....	5			
7.1.1	Normal mode .....	5			
7.1.2	Standby mode .....	5			
7.2	Fail-safe features .....	5			
7.2.1	TXD dominant time-out function .....	5			
7.2.2	Undervoltage protection: $V_{DD2}$ .....	5			
7.2.3	Undervoltage protection: $V_{DD1}$ .....	6			
7.2.4	Overtemperature protection .....	6			
7.3	Insulation characteristics and safety-related specifications .....	6			
<b>8</b>	<b>Limiting values</b> .....	<b>8</b>			
<b>9</b>	<b>Thermal characteristics</b> .....	<b>8</b>			
<b>10</b>	<b>Static characteristics</b> .....	<b>9</b>			
<b>11</b>	<b>Dynamic characteristics</b> .....	<b>11</b>			
<b>12</b>	<b>Application information</b> .....	<b>13</b>			
12.1	Application hints .....	13			
<b>13</b>	<b>Test information</b> .....	<b>13</b>			
13.1	Quality information .....	13			
13.2	Test circuits .....	14			
<b>14</b>	<b>Package outline</b> .....	<b>15</b>			
<b>15</b>	<b>Handling information</b> .....	<b>16</b>			
<b>16</b>	<b>Soldering of SMD packages</b> .....	<b>16</b>			
16.1	Introduction to soldering .....	16			
16.2	Wave and reflow soldering .....	16			
16.3	Wave soldering .....	16			
16.4	Reflow soldering .....	17			
<b>17</b>	<b>Revision history</b> .....	<b>18</b>			
<b>18</b>	<b>Legal information</b> .....	<b>19</b>			
18.1	Data sheet status .....	19			
18.2	Definitions .....	19			
18.3	Disclaimers .....	19			
18.4	Trademarks .....	20			

Please be aware that important notices concerning this document and the product(s) described herein, have been included in section 'Legal information'.

© NXP N.V. 2015.

All rights reserved.

For more information, please visit: <http://www.nxp.com>

For sales office addresses, please send an email to: [salesaddresses@nxp.com](mailto:salesaddresses@nxp.com)

Date of release: 19 January 2015

Document identifier: TJA1052I

# Mouser Electronics

Authorized Distributor

Click to View Pricing, Inventory, Delivery & Lifecycle Information:

[NXP:](#)

[TJA1052IT/2Y](#) [TJA1052IT/1Y](#) [TJA1052IT/5Y](#)