



# STD12N65M5, STF12N65M5, STI12N65M5 STP12N65M5, STU12N65M5

N-channel 650 V, 0.39  $\Omega$ , 8.5 A MDmesh™ V Power MOSFET  
DPAK, I<sup>2</sup>PAK, TO-220FP, TO-220, IPAK

## Features

Type	V <sub>DSS</sub> @ T <sub>Jmax</sub>	R <sub>DS(on)</sub> max	I <sub>D</sub>	P <sub>TOT</sub>
STD12N65M5	710 V	< 0.43 $\Omega$	8.5 A	70 W
STF12N65M5			8.5 A <sup>(1)</sup>	25 W
STI12N65M5			8.5 A	70 W
STP12N65M5			8.5 A	70 W
STU12N65M5			8.5 A	70 W

1. Limited only by maximum temperature allowed.

- Worldwide best R<sub>DS(on)</sub> \* area
- Higher V<sub>DSS</sub> rating and high dv/dt capability
- Excellent switching performance
- Easy to drive
- 100% avalanche tested

## Applications

Switching applications

## Description

These devices are N-channel MDmesh™ V Power MOSFETs based on an innovative proprietary vertical process technology, which is combined with STMicroelectronics' well-known PowerMESH™ horizontal layout structure. The resulting product has extremely low on-resistance, which is unmatched among silicon-based Power MOSFETs, making it especially suitable for applications which require superior power density and outstanding efficiency.

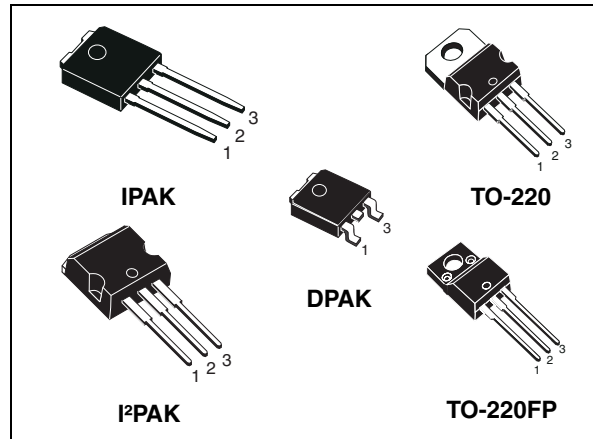

Figure 1. Internal schematic diagram

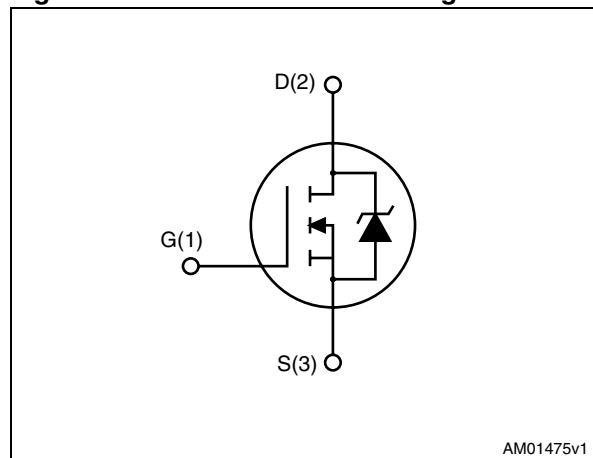

Table 1. Device summary

Order codes	Marking	Packages	Packaging
STD12N65M5	12N65M5	DPAK	Tape and reel
STF12N65M5		TO-220FP	Tube
STI12N65M5		I <sup>2</sup> PAK	Tube
STP12N65M5		TO-220	Tube
STU12N65M5		IPAK	Tube

# Contents

<b>1</b>	<b>Electrical ratings</b> .....	<b>3</b>
<b>2</b>	<b>Electrical characteristics</b> .....	<b>4</b>
2.1	Electrical characteristics (curves) .....	6
<b>3</b>	<b>Test circuits</b> .....	<b>9</b>
<b>4</b>	<b>Package mechanical data</b> .....	<b>10</b>
<b>5</b>	<b>Packaging mechanical data</b> .....	<b>20</b>
<b>6</b>	<b>Revision history</b> .....	<b>22</b>

# 1 Electrical ratings

**Table 2. Absolute maximum ratings**

Symbol	Parameter	Value		Unit
		TO-220, IPAK, DPAK, I <sup>2</sup> PAK	TO-220FP	
V <sub>DS</sub>	Drain-source voltage (V <sub>GS</sub> = 0)	650		V
V <sub>GS</sub>	Gate-source voltage	25		V
I <sub>D</sub>	Drain current (continuous) at T <sub>C</sub> = 25 °C	8.5	8.5 <sup>(1)</sup>	A
I <sub>D</sub>	Drain current (continuous) at T <sub>C</sub> = 100 °C	5.4	5.4 <sup>(1)</sup>	A
I <sub>DM</sub> <sup>(2)</sup>	Drain current (pulsed)	34	34 <sup>(1)</sup>	A
P <sub>TOT</sub>	Total dissipation at T <sub>C</sub> = 25 °C	70	25	W
I <sub>AR</sub>	Avalanche current, repetitive or not-repetitive (pulse width limited by T <sub>j</sub> max)	2.5		A
E <sub>AS</sub>	Single pulse avalanche energy (starting T <sub>j</sub> = 25 °C, I <sub>D</sub> = I <sub>AR</sub> , V <sub>DD</sub> = 50 V)	150		mJ
dv/dt <sup>(3)</sup>	Peak diode recovery voltage slope	15		V/ns
V <sub>ISO</sub>	Insulation withstand voltage (RMS) from all three leads to external heat sink (t = 1 s; T <sub>C</sub> = 25 °C)		2500	V
T <sub>stg</sub>	Storage temperature	- 55 to 150		°C
T <sub>j</sub>	Max. operating junction temperature	150		°C

1. Limited only by maximum temperature allowed.
2. Pulse width limited by safe operating area.
3. I<sub>SD</sub> ≤ 8.5 A, di/dt ≤ 400 A/μs; V<sub>Peak</sub> < V<sub>(BR)DSS</sub>, V<sub>DD</sub> = 400 V

**Table 3. Thermal data**

Symbol	Parameter	Value					Unit
		DPAK	IPAK	I <sup>2</sup> PAK	TO-220	TO-220FP	
R <sub>thj-case</sub>	Thermal resistance junction-case max	1.79			5	°C/W	
R <sub>thj-amb</sub>	Thermal resistance junction-ambient max		100	62.5		°C/W	
R <sub>thj-pcb</sub> <sup>(1)</sup>	Thermal resistance junction-pcb max	50				°C/W	
T <sub>l</sub>	Maximum lead temperature for soldering purpose	300				°C	

1. When mounted on 1inch<sup>2</sup> FR-4 board, 2 oz Cu

## 2 Electrical characteristics

( $T_C = 25\text{ °C}$  unless otherwise specified)

**Table 4. On /off states**

Symbol	Parameter	Test conditions	Min.	Typ.	Max.	Unit
$V_{(BR)DSS}$	Drain-source breakdown voltage	$I_D = 1\text{ mA}$ , $V_{GS} = 0$	650			V
$I_{DSS}$	Zero gate voltage drain current ( $V_{GS} = 0$ )	$V_{DS} = \text{Max rating}$ $V_{DS} = \text{Max rating}$ , $T_C = 125\text{ °C}$			1 100	$\mu\text{A}$ $\mu\text{A}$
$I_{GSS}$	Gate-body leakage current ( $V_{DS} = 0$ )	$V_{GS} = \pm 25\text{ V}$			100	nA
$V_{GS(th)}$	Gate threshold voltage	$V_{DS} = V_{GS}$ , $I_D = 250\text{ }\mu\text{A}$	3	4	5	V
$R_{DS(on)}$	Static drain-source on resistance	$V_{GS} = 10\text{ V}$ , $I_D = 4.3\text{ A}$		0.39	0.43	$\Omega$

**Table 5. Dynamic**

Symbol	Parameter	Test conditions	Min.	Typ.	Max.	Unit
$C_{iss}$	Input capacitance	$V_{DS} = 100\text{ V}$ , $f = 1\text{ MHz}$ , $V_{GS} = 0$	-	900	-	pF
$C_{oss}$	Output capacitance			22		pF
$C_{rss}$	Reverse transfer capacitance			2		pF
$C_{o(tr)}^{(1)}$	Equivalent capacitance time related	$V_{DS} = 0\text{ to }520\text{ V}$ , $V_{GS} = 0$	-	64	-	pF
$C_{o(er)}^{(2)}$	Equivalent capacitance energy related			21		pF
$R_G$	Intrinsic gate resistance	$f = 1\text{ MHz}$ open drain	-	2.5	-	$\Omega$
$Q_g$	Total gate charge	$V_{DD} = 520\text{ V}$ , $I_D = 4.25\text{ A}$ , $V_{GS} = 10\text{ V}$ (see <a href="#">Figure 20</a> )	-	20	-	nC
$Q_{gs}$	Gate-source charge			4.8		nC
$Q_{gd}$	Gate-drain charge			8.3		nC

1. Time related is defined as a constant equivalent capacitance giving the same charging time as  $C_{oss}$  when  $V_{DS}$  increases from 0 to 80%  $V_{DSS}$
2. Energy related is defined as a constant equivalent capacitance giving the same stored energy as  $C_{oss}$  when  $V_{DS}$  increases from 0 to 80%  $V_{DSS}$

**Table 6. Switching times**

Symbol	Parameter	Test conditions	Min.	Typ.	Max	Unit
$t_d$ (v)	Voltage delay time	$V_{DD} = 400$ V, $I_D = 5$ A,		22.6		ns
$t_r$ (v)	Voltage rise time	$R_G = 4.7$ $\Omega$ , $V_{GS} = 10$ V		17.6		ns
$t_f$ (i)	Current fall time	(see <a href="#">Figure 21</a> and		15.6		ns
$t_c$ (off)	Crossing time	<a href="#">Figure 24</a> )		23.4		ns

**Table 7. Source drain diode**

Symbol	Parameter	Test conditions	Min.	Typ.	Max.	Unit
$I_{SD}$	Source-drain current				8.5	A
$I_{SDM}^{(1)}$	Source-drain current (pulsed)				34	A
$V_{SD}^{(2)}$	Forward on voltage	$I_{SD} = 8.5$ A, $V_{GS} = 0$			1.5	V
$t_{rr}$	Reverse recovery time	$I_{SD} = 8.5$ A, $di/dt = 100$ A/ $\mu$ s		230		ns
$Q_{rr}$	Reverse recovery charge	$V_{DD} = 100$ V (see <a href="#">Figure 24</a> )		2.2		$\mu$ C
$I_{RRM}$	Reverse recovery current			19		A
$t_{rr}$	Reverse recovery time	$I_{SD} = 8.5$ A, $di/dt = 100$ A/ $\mu$ s		280		ns
$Q_{rr}$	Reverse recovery charge	$V_{DD} = 100$ V, $T_j = 150$ °C		2.7		$\mu$ C
$I_{RRM}$	Reverse recovery current	(see <a href="#">Figure 24</a> )		19		A

1. Pulse width limited by safe operating area
2. Pulsed: pulse duration = 300  $\mu$ s, duty cycle 1.5%

## 2.1 Electrical characteristics (curves)

Figure 2. Safe operating area for TO-220 and I<sup>2</sup>PAK

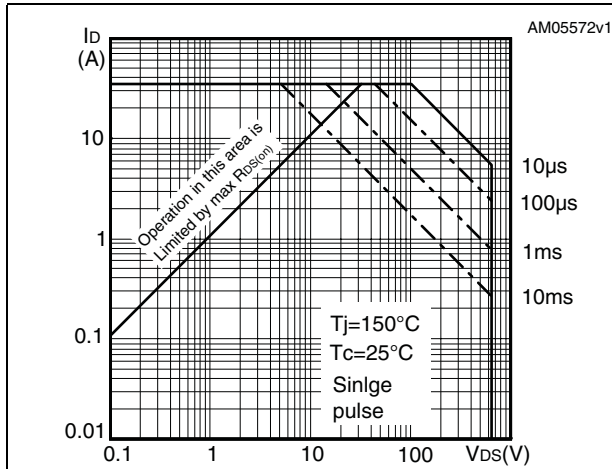

Figure 3. Thermal impedance for TO-220 and I<sup>2</sup>PAK

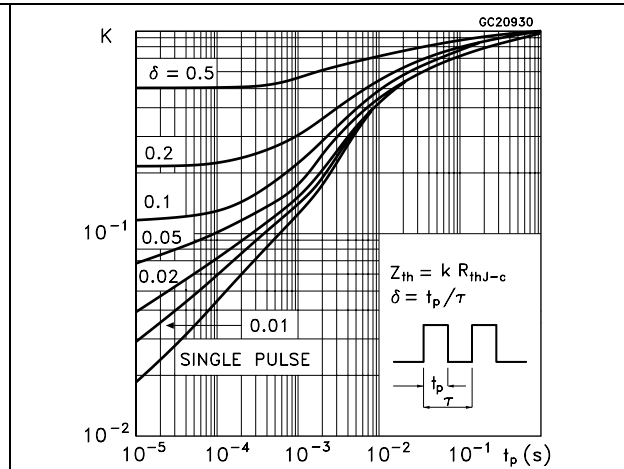

Figure 4. Safe operating area for TO-220FP

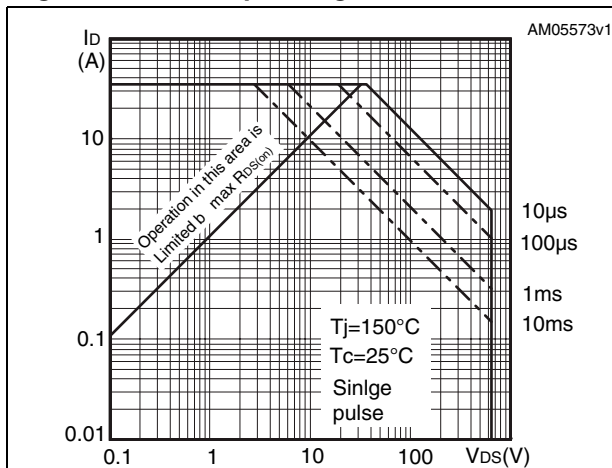

Figure 5. Thermal impedance for TO-220FP

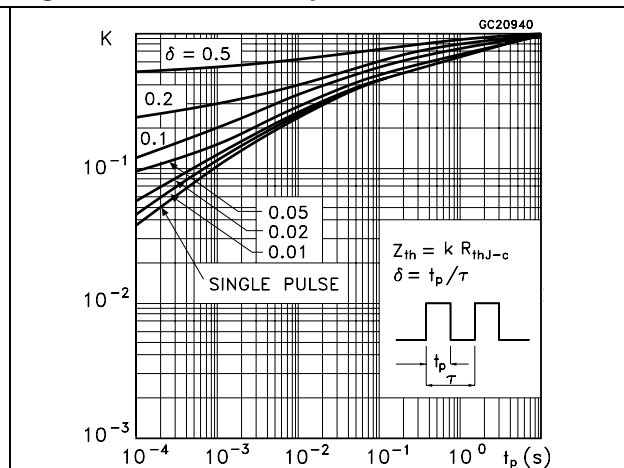

Figure 6. Safe operating area for DPAK, IPAK

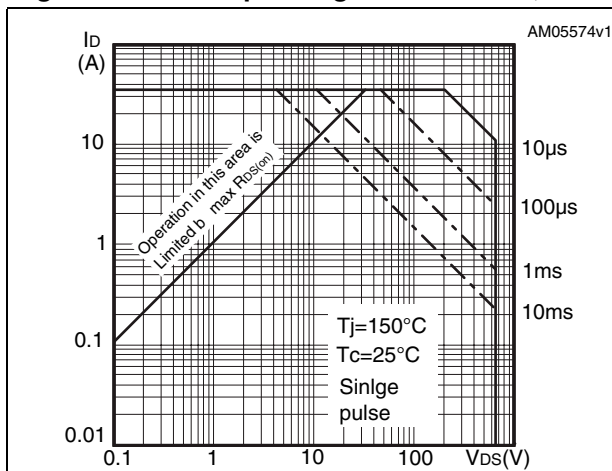

Figure 7. Thermal impedance for DPAK, IPAK

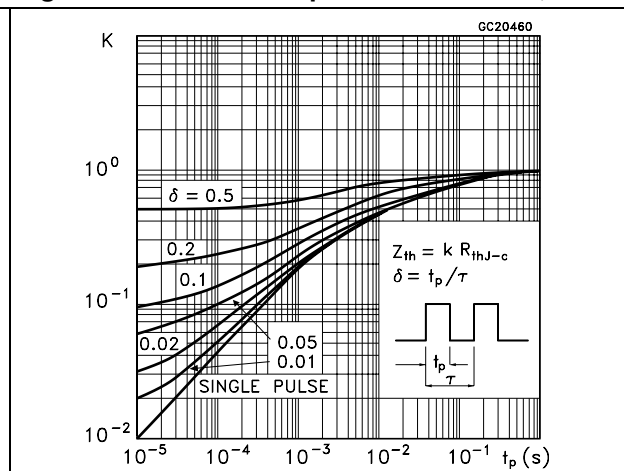

Figure 8. Output characteristics

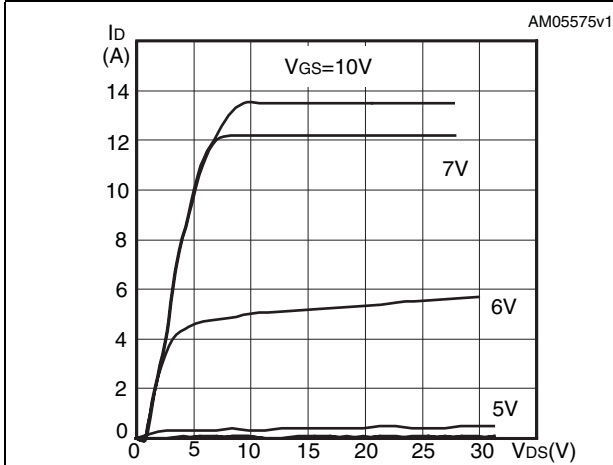

Figure 9. Transfer characteristics

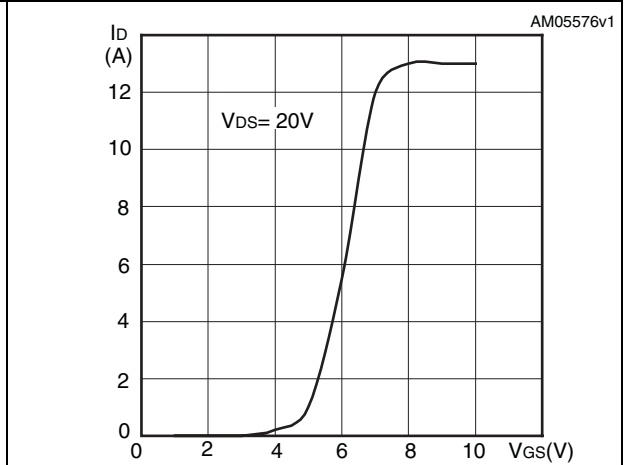

Figure 10. Gate charge vs gate-source voltage

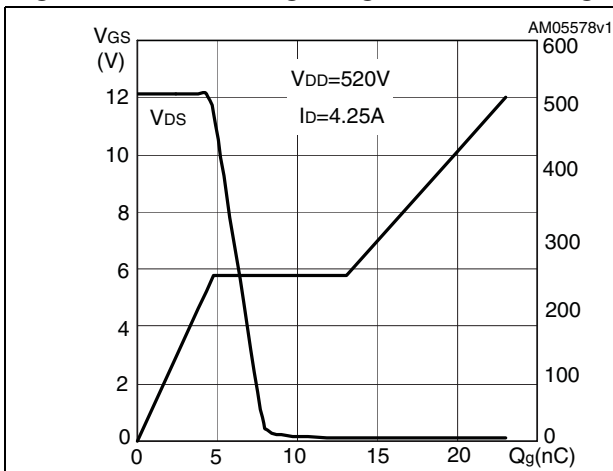

Figure 11. Static drain-source on resistance

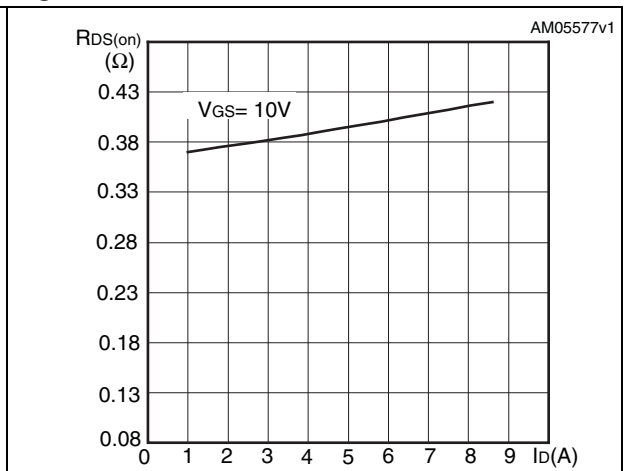

Figure 12. Capacitance variations

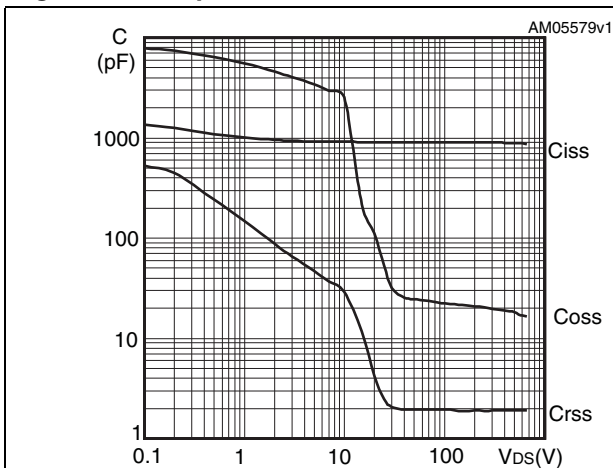

Figure 13. Output capacitance stored energy

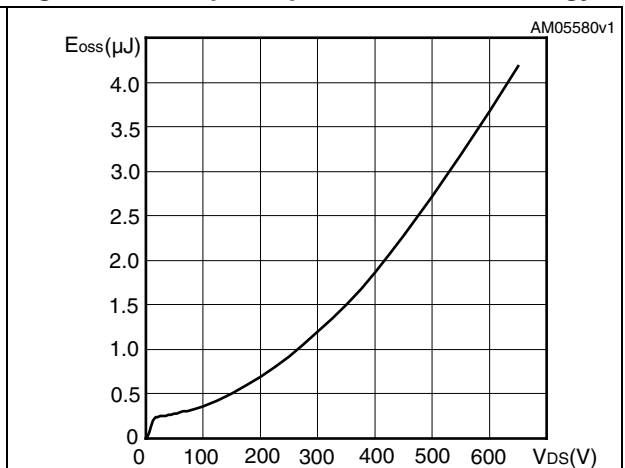

Figure 14. Normalized gate threshold voltage vs temperature

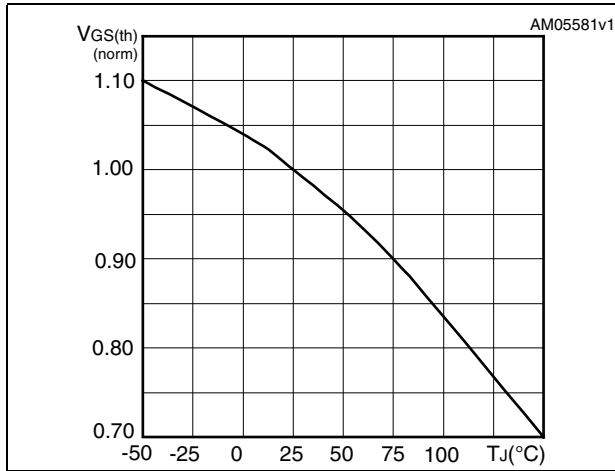

Figure 15. Normalized on resistance vs temperature

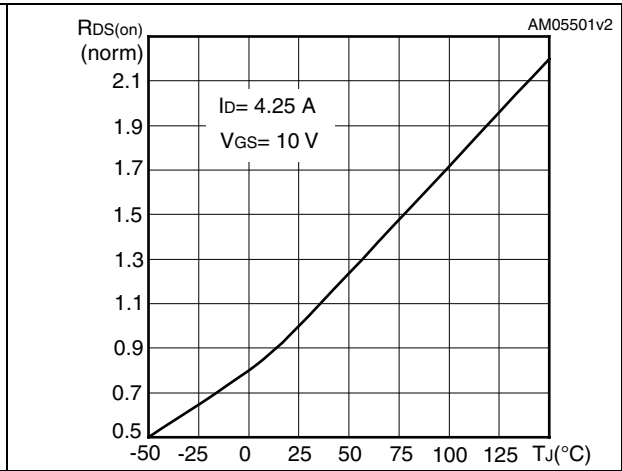

Figure 16. Source-drain diode forward characteristics

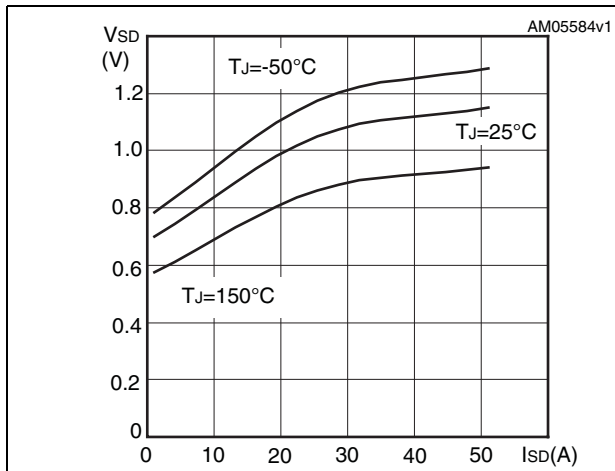

Figure 17. Normalized BV<sub>DSS</sub> @ 1 mA vs temperature

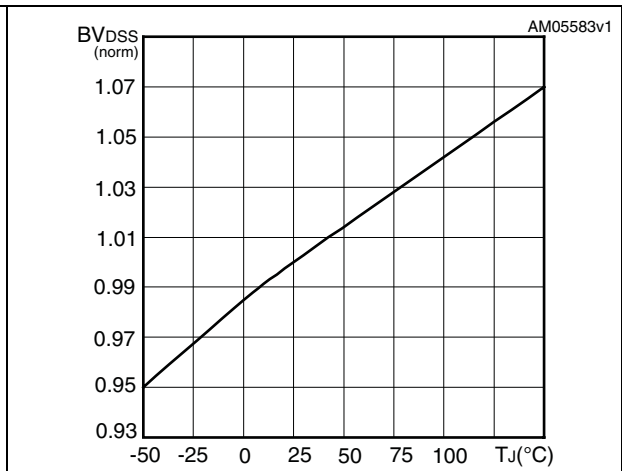
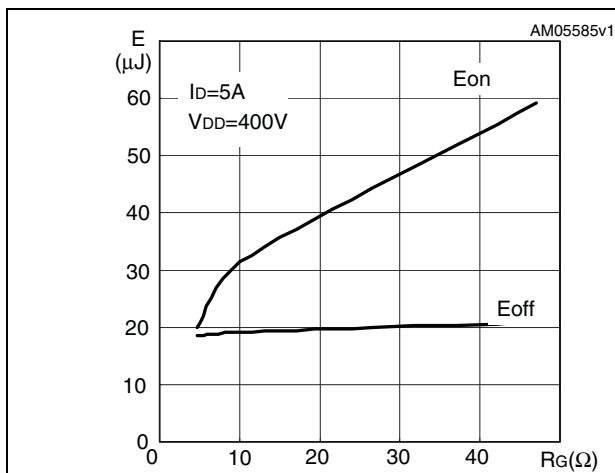

Figure 18. Switching losses vs gate resistance (1)



1. Eon including reverse recovery of a SiC diode



### 3 Test circuits

**Figure 19. Switching times test circuit for resistive load**

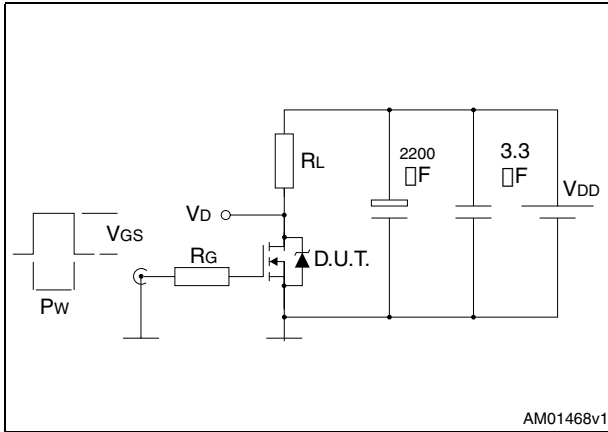

**Figure 20. Gate charge test circuit**

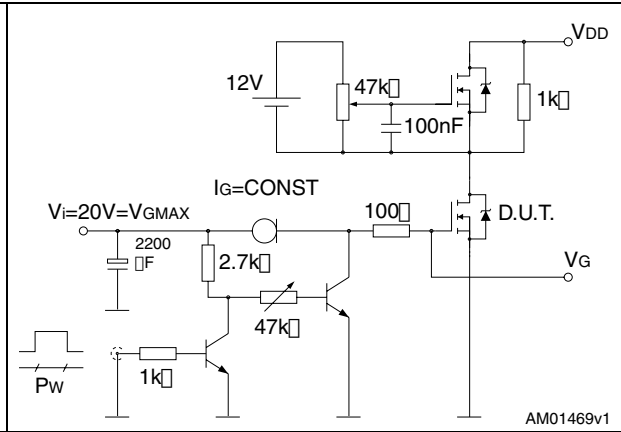

**Figure 21. Test circuit for inductive load switching and diode recovery times**

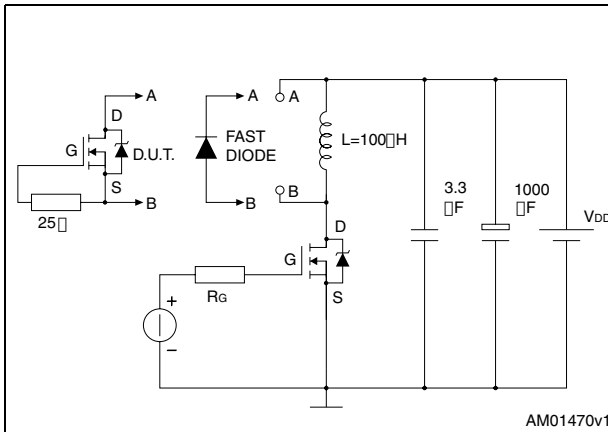

**Figure 22. Unclamped inductive load test circuit**

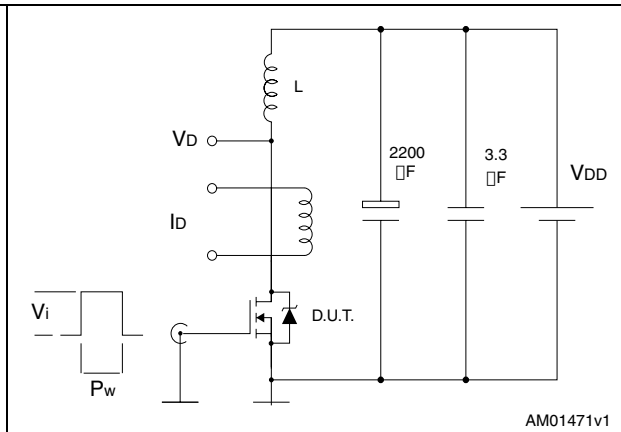

**Figure 23. Unclamped inductive waveform**

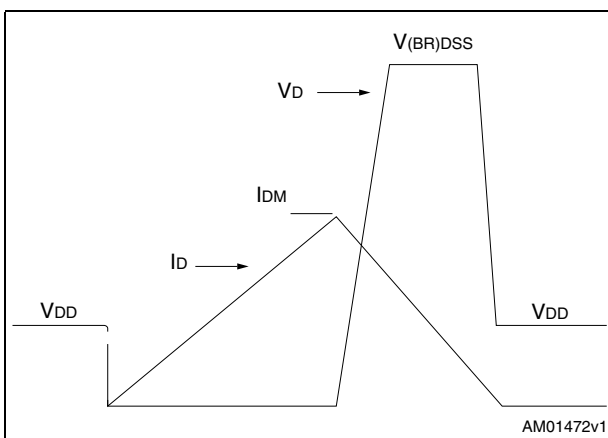

**Figure 24. Switching time waveform**

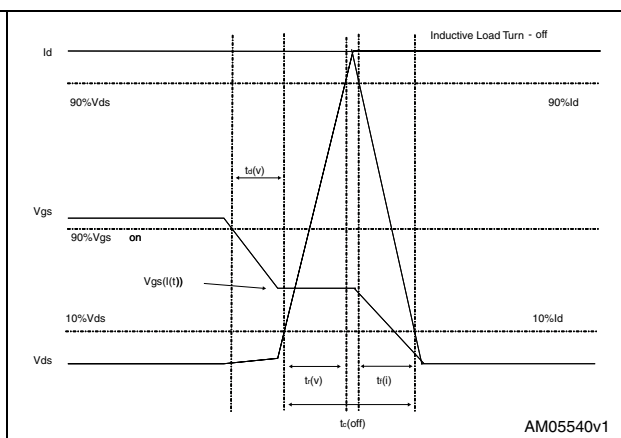

## 4 Package mechanical data

In order to meet environmental requirements, ST offers these devices in different grades of ECOPACK® packages, depending on their level of environmental compliance. ECOPACK® specifications, grade definitions and product status are available at: [www.st.com](http://www.st.com). ECOPACK is an ST trademark.

Table 8. DPAK (TO-252) mechanical data

Dim.	mm		
	Min.	Typ.	Max.
A	2.20		2.40
A1	0.90		1.10
A2	0.03		0.23
b	0.64		0.90
b4	5.20		5.40
c	0.45		0.60
c2	0.48		0.60
D	6.00		6.20
D1		5.10	
E	6.40		6.60
E1		4.70	
e		2.28	
e1	4.40		4.60
H	9.35		10.10
L	1		1.50
L1		2.80	
L2		0.80	
L4	0.60		1
R		0.20	
V2	0°		8°

Figure 25. DPAK (TO-252) drawing

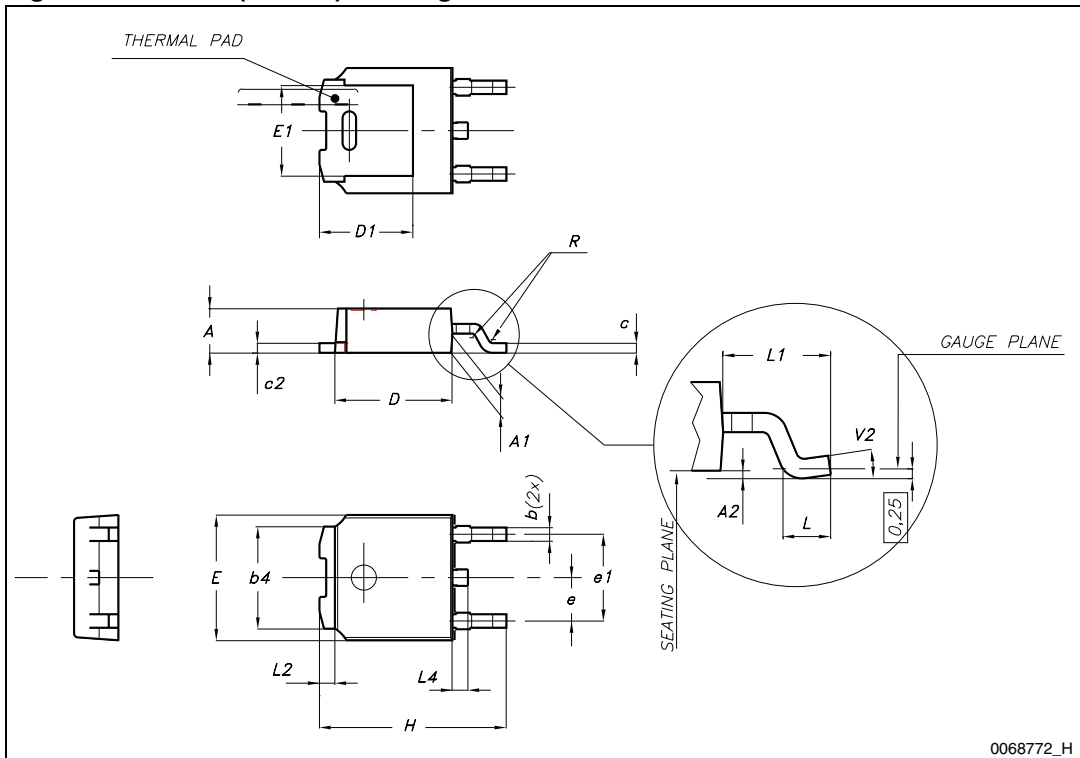
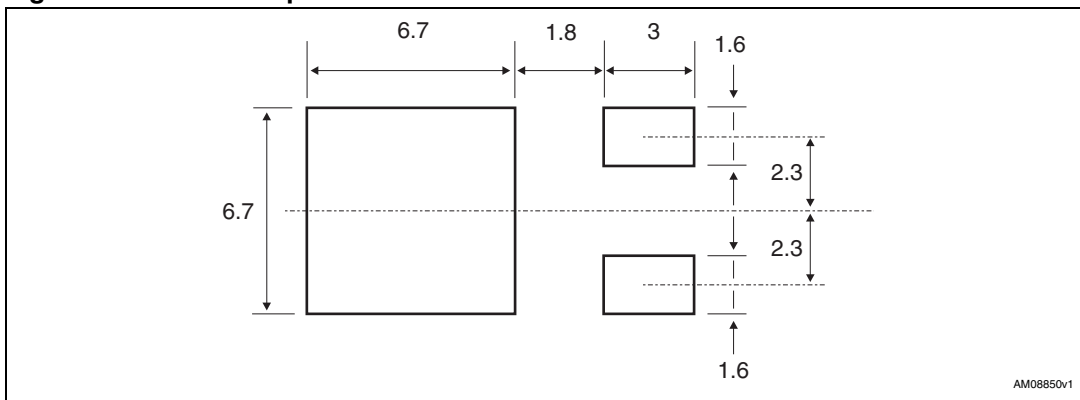

Figure 26. DPAK footprint<sup>(a)</sup>



a. All dimension are in millimeters

Table 9. IPAK (TO-251) mechanical data

DIM.	mm.		
	min.	typ	max.
A	2.20		2.40
A1	0.90		1.10
b	0.64		0.90
b2			0.95
b4	5.20		5.40
B5		0.3	
c	0.45		0.60
c2	0.48		0.60
D	6.00		6.20
E	6.40		6.60
e		2.28	
e1	4.40		4.60
H		16.10	
L	9.00		9.40
L1	0.80		1.20
L2		0.80	1.00
V1		10°	

Figure 27. IPAK (TO-251) drawing

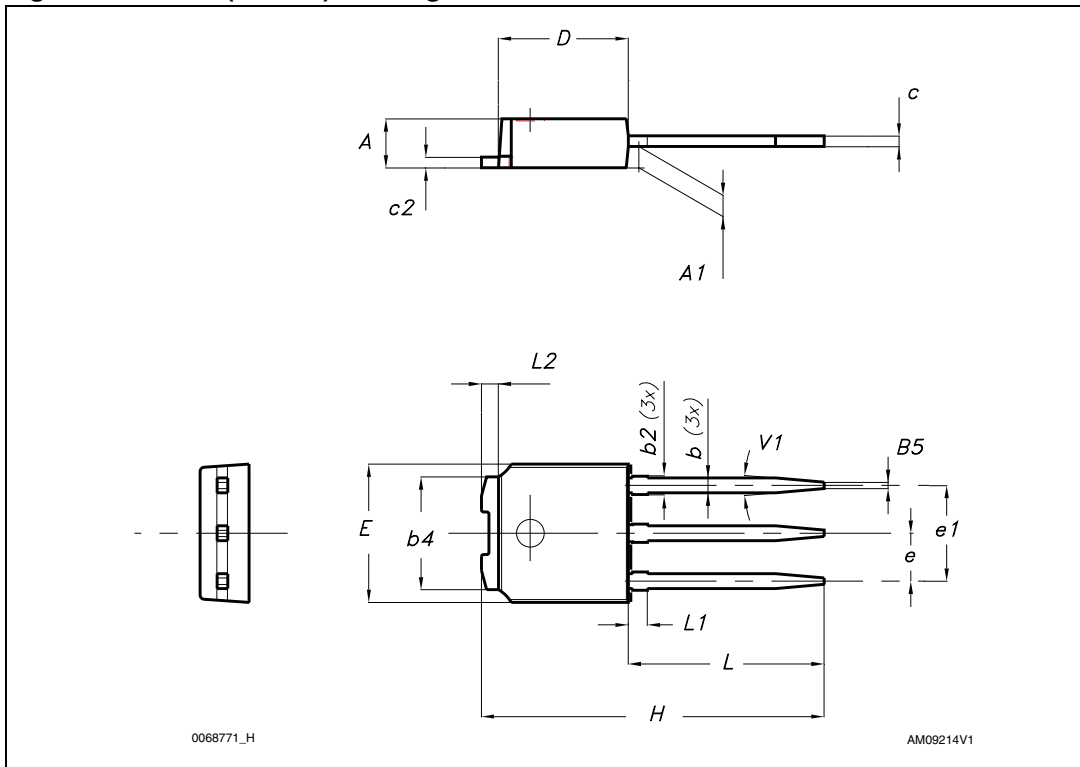
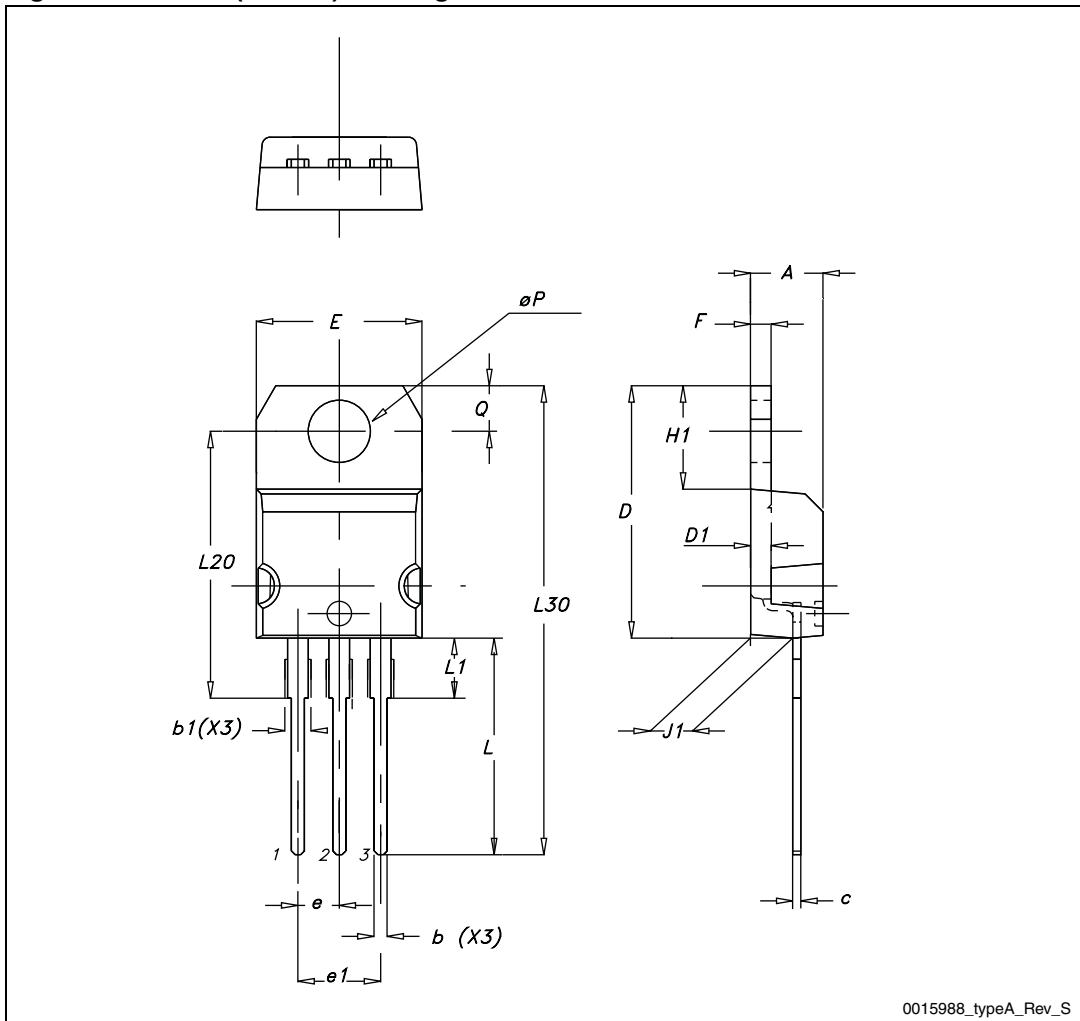

Table 10. I<sup>2</sup>PAK (TO-262) mechanical data

DIM.	mm.		
	min.	typ	max.
A	4.40		4.60
A1	2.40		2.72
b	0.61		0.88
b1	1.14		1.70
c	0.49		0.70
c2	1.23		1.32
D	8.95		9.35
e	2.40		2.70
e1	4.95		5.15
E	10		10.40
L	13		14
L1	3.50		3.93
L2	1.27		1.40

Figure 28. I<sup>2</sup>PAK (TO-262) drawing



0015988\_typeA\_Rev\_S



Table 11. TO-220 type A mechanical data

Dim.	mm		
	Min.	Typ.	Max.
A	4.40		4.60
b	0.61		0.88
b1	1.14		1.70
c	0.48		0.70
D	15.25		15.75
D1		1.27	
E	10		10.40
e	2.40		2.70
e1	4.95		5.15
F	1.23		1.32
H1	6.20		6.60
J1	2.40		2.72
L	13		14
L1	3.50		3.93
L20		16.40	
L30		28.90	
ØP	3.75		3.85
Q	2.65		2.95

Figure 29. TO-220 type A drawing

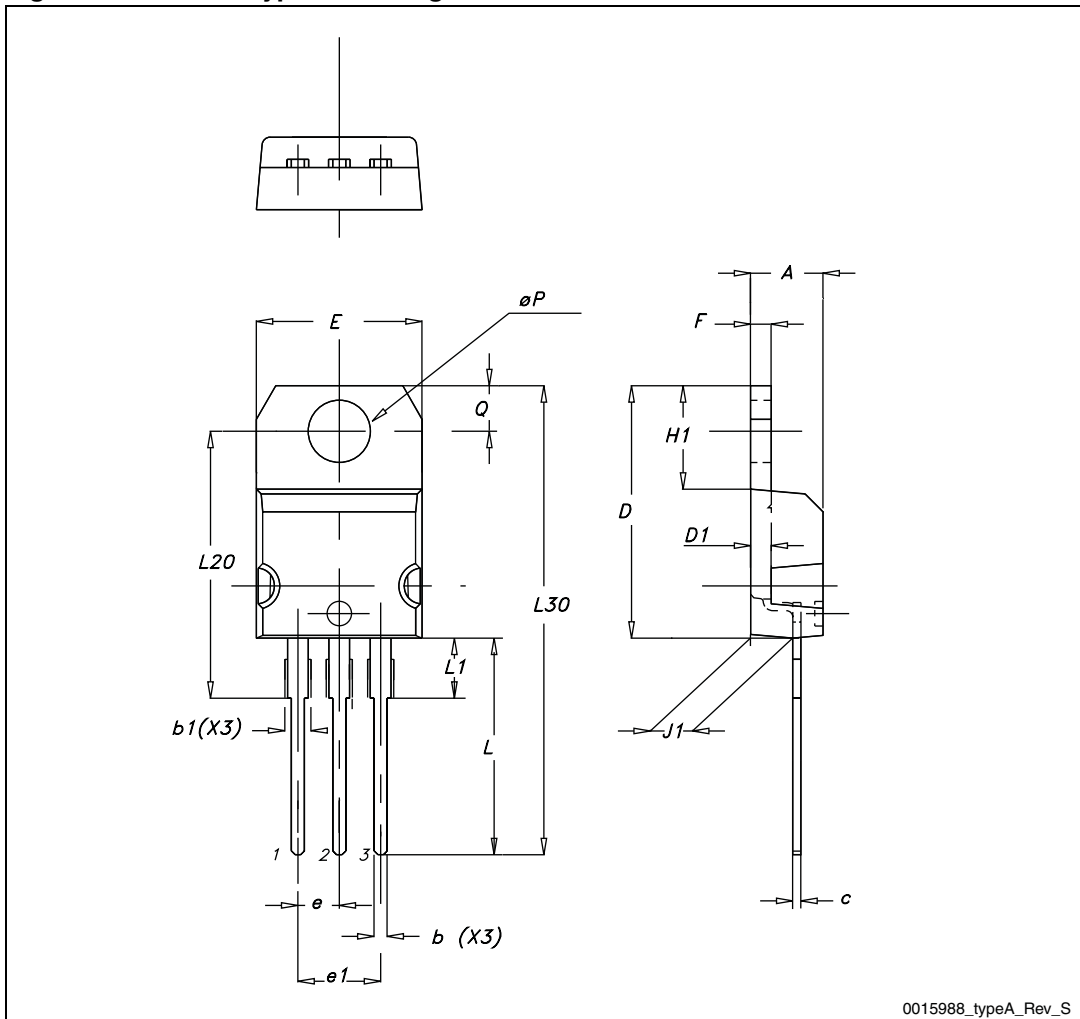
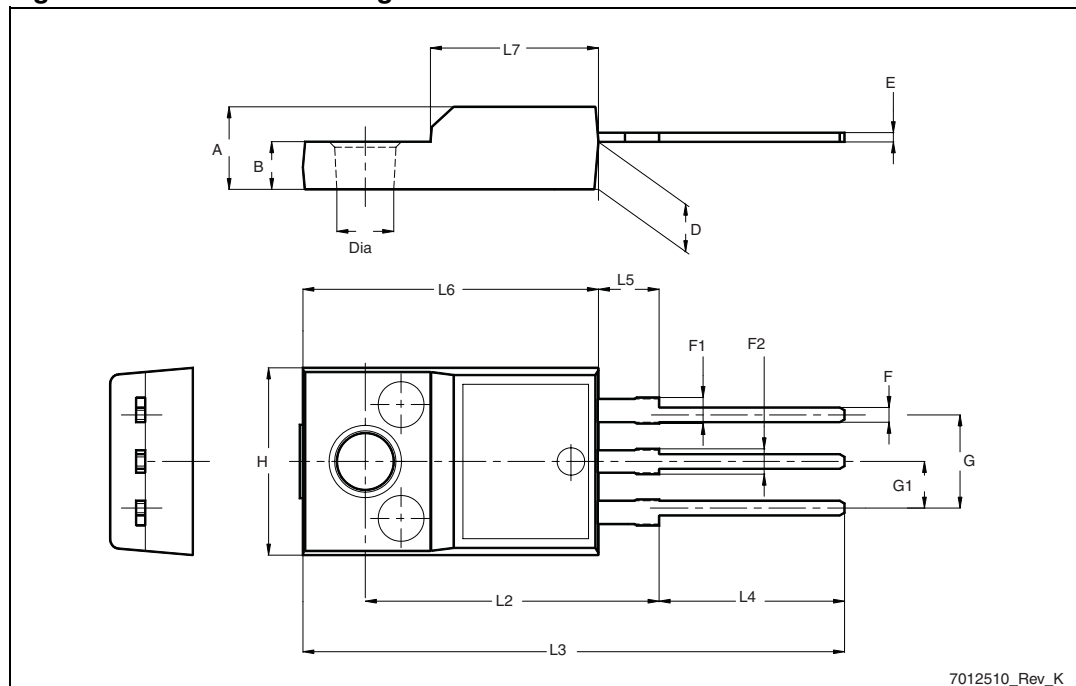

Table 12. TO-220FP mechanical data

Dim.	mm		
	Min.	Typ.	Max.
A	4.4		4.6
B	2.5		2.7
D	2.5		2.75
E	0.45		0.7
F	0.75		1
F1	1.15		1.70
F2	1.15		1.70
G	4.95		5.2
G1	2.4		2.7
H	10		10.4
L2		16	
L3	28.6		30.6
L4	9.8		10.6
L5	2.9		3.6
L6	15.9		16.4
L7	9		9.3
Dia	3		3.2

Figure 30. TO-220FP drawing



## 5 Packaging mechanical data

Table 13. DPAK (TO-252) tape and reel mechanical data

Tape			Reel		
Dim.	mm		Dim.	mm	
	Min.	Max.		Min.	Max.
A0	6.8	7	A		330
B0	10.4	10.6	B	1.5	
B1		12.1	C	12.8	13.2
D	1.5	1.6	D	20.2	
D1	1.5		G	16.4	18.4
E	1.65	1.85	N	50	
F	7.4	7.6	T		22.4
K0	2.55	2.75			
P0	3.9	4.1	Base qty.		2500
P1	7.9	8.1	Bulk qty.		2500
P2	1.9	2.1			
R	40				
T	0.25	0.35			
W	15.7	16.3			

Figure 31. Tape

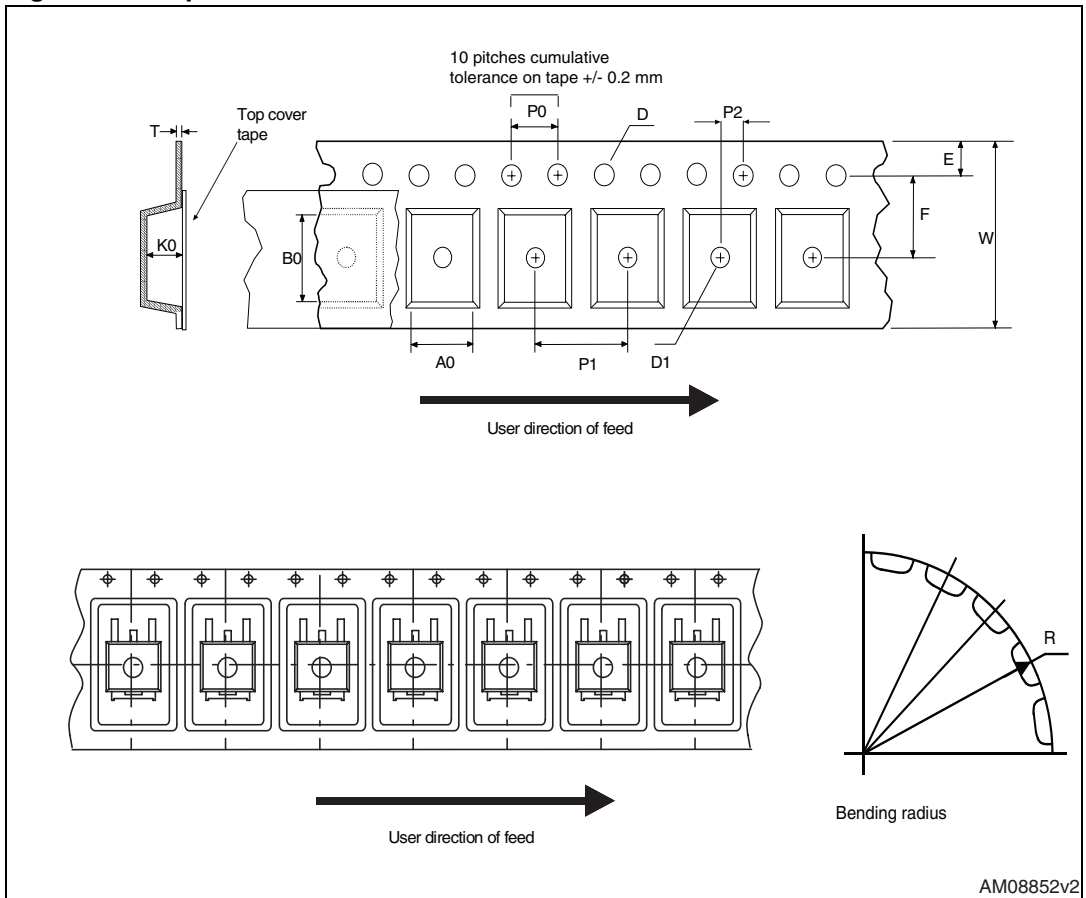
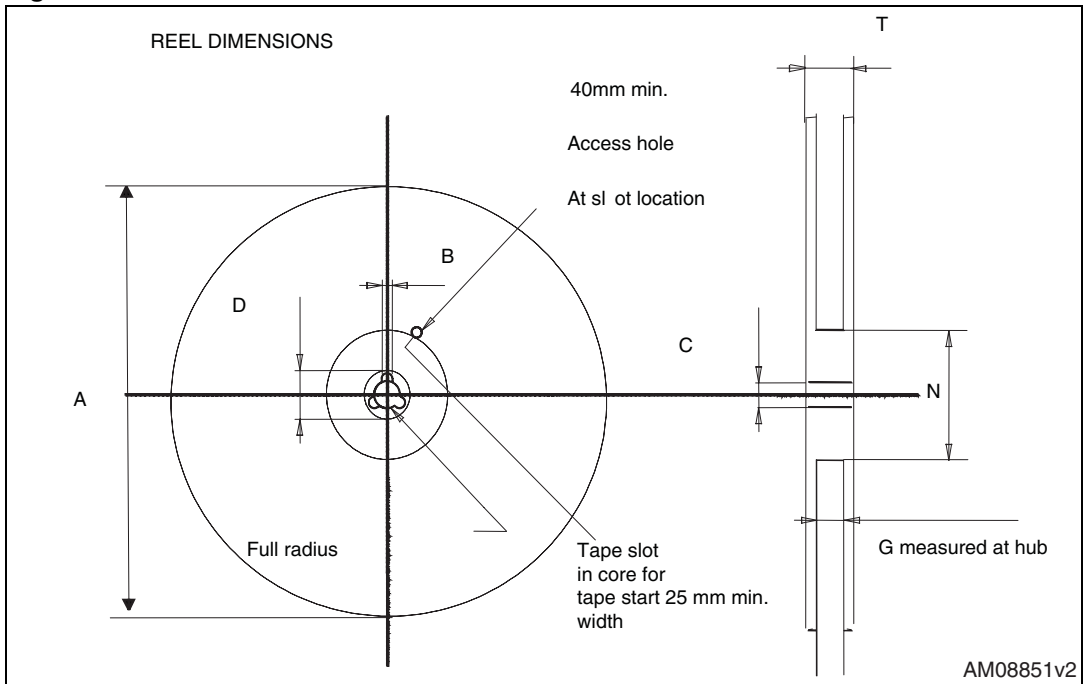

Figure 32. Reel



## 6 Revision history

**Table 14. Document revision history**

Date	Revision	Changes
24-Feb-2009	1	First release
27-Feb-2009	2	Corrected package information on first page
21-Jan-2010	3	Document status promoted from preliminary data to datasheet
29-Jun-2010	4	<ul style="list-style-type: none"><li>– <i>Figure 15: Normalized on resistance vs temperature</i> has been updated</li><li>– <math>V_{GS}</math> vale in <i>Table 4</i> has been corrected</li></ul>
22-Jun-2011	5	Updated <i>Figure 18</i> and <i>Figure 20</i> . Updated gate charge in <i>Table 5</i> and switching time in <i>Table 6</i> .

**Please Read Carefully:**

Information in this document is provided solely in connection with ST products. STMicroelectronics NV and its subsidiaries ("ST") reserve the right to make changes, corrections, modifications or improvements, to this document, and the products and services described herein at any time, without notice.

All ST products are sold pursuant to ST's terms and conditions of sale.

Purchasers are solely responsible for the choice, selection and use of the ST products and services described herein, and ST assumes no liability whatsoever relating to the choice, selection or use of the ST products and services described herein.

No license, express or implied, by estoppel or otherwise, to any intellectual property rights is granted under this document. If any part of this document refers to any third party products or services it shall not be deemed a license grant by ST for the use of such third party products or services, or any intellectual property contained therein or considered as a warranty covering the use in any manner whatsoever of such third party products or services or any intellectual property contained therein.

**UNLESS OTHERWISE SET FORTH IN ST'S TERMS AND CONDITIONS OF SALE ST DISCLAIMS ANY EXPRESS OR IMPLIED WARRANTY WITH RESPECT TO THE USE AND/OR SALE OF ST PRODUCTS INCLUDING WITHOUT LIMITATION IMPLIED WARRANTIES OF MERCHANTABILITY, FITNESS FOR A PARTICULAR PURPOSE (AND THEIR EQUIVALENTS UNDER THE LAWS OF ANY JURISDICTION), OR INFRINGEMENT OF ANY PATENT, COPYRIGHT OR OTHER INTELLECTUAL PROPERTY RIGHT.**

**UNLESS EXPRESSLY APPROVED IN WRITING BY AN AUTHORIZED ST REPRESENTATIVE, ST PRODUCTS ARE NOT RECOMMENDED, AUTHORIZED OR WARRANTED FOR USE IN MILITARY, AIR CRAFT, SPACE, LIFE SAVING, OR LIFE SUSTAINING APPLICATIONS, NOR IN PRODUCTS OR SYSTEMS WHERE FAILURE OR MALFUNCTION MAY RESULT IN PERSONAL INJURY, DEATH, OR SEVERE PROPERTY OR ENVIRONMENTAL DAMAGE. ST PRODUCTS WHICH ARE NOT SPECIFIED AS "AUTOMOTIVE GRADE" MAY ONLY BE USED IN AUTOMOTIVE APPLICATIONS AT USER'S OWN RISK.**

Resale of ST products with provisions different from the statements and/or technical features set forth in this document shall immediately void any warranty granted by ST for the ST product or service described herein and shall not create or extend in any manner whatsoever, any liability of ST.

ST and the ST logo are trademarks or registered trademarks of ST in various countries.

Information in this document supersedes and replaces all information previously supplied.

The ST logo is a registered trademark of STMicroelectronics. All other names are the property of their respective owners.

© 2011 STMicroelectronics - All rights reserved

STMicroelectronics group of companies

Australia - Belgium - Brazil - Canada - China - Czech Republic - Finland - France - Germany - Hong Kong - India - Israel - Italy - Japan - Malaysia - Malta - Morocco - Philippines - Singapore - Spain - Sweden - Switzerland - United Kingdom - United States of America

[www.st.com](http://www.st.com)



# Mouser Electronics

Authorized Distributor

Click to View Pricing, Inventory, Delivery & Lifecycle Information:

[STMicroelectronics:](#)

[STF12N65M5](#) [STP12N65M5](#)